

Phase Change Materials

Temperature Thresholds During Phase Changes

Definitions

Enthalpy = The sum of the internal energy of the system plus the product of the pressure of the gas in the system and its volume

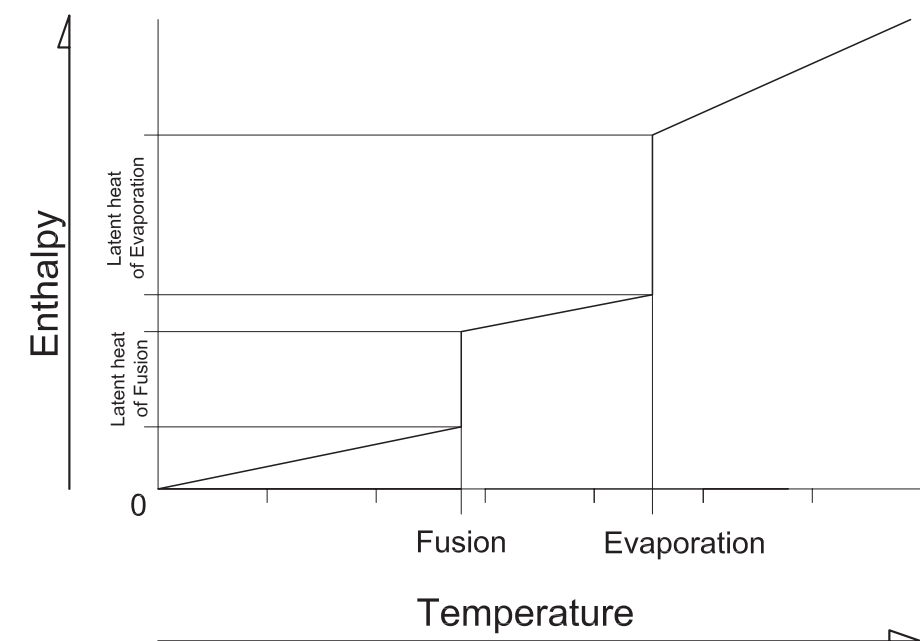

As a material receives energy from its environment, its temperature will increase in a linear relationship until it reaches a critical threshold, or phase boundary. At this threshold, the material begins to absorb energy without changing temperature, while undergoing physical transformations. The material resumes a linear temperature relationship after the phase change is complete.

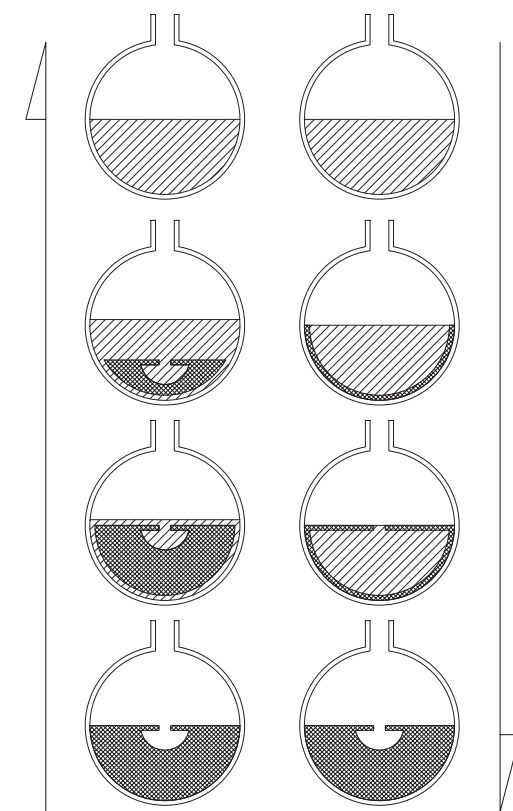

Freezing

During the process of freezing inside of a fixed container, the wax PCM first freezes to the exterior surface of the container. As the PCM continues to freeze, the material shrinks and voids are formed inside of the container.

Physical Properties

Phase Change Materials (PCMs) are materials that are chosen specifically for the properties they exhibit during a change in phase. In water, this may include storage of latent heat (such as ice cubes) or the exertion pressure (such as in a steam engine.)

Common Phase Change Materials

Water

Water is a commonly used phase change material. The pressure generated by water when it freezes is responsible for cracks in both mountains and pavement.

Paraffin Wax

Paraffin wax is a blend of organic compounds chosen for their melting and freezing characteristics. The material is sold as a PCM embedded in garments and building materials.

Salt Compounds

Salt mixtures are also used to absorb latent heat. They often have a very high latent heat of fusion, but can be difficult to contain due to some corrosive qualities.

Polyethylene Glycol

Polyethylene Glycol is manufactured in large quantities for use in pharmaceuticals. The melting temperature is related to the length of the polymer chains, with longer chains melting at higher temperatures.

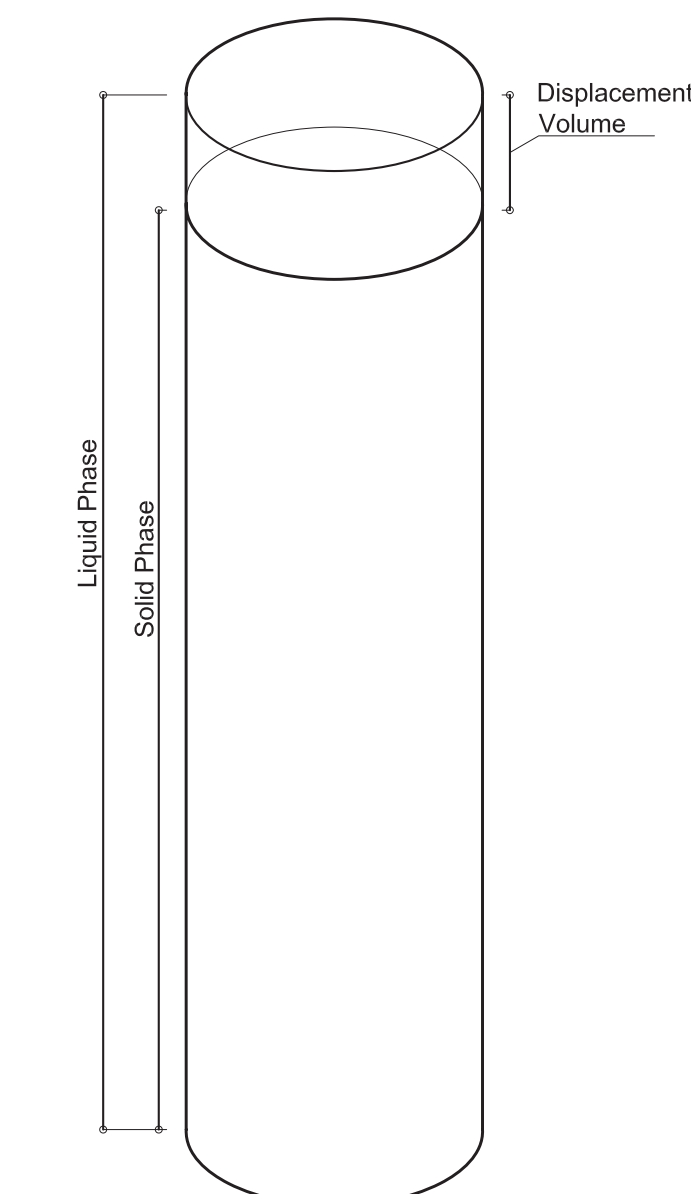

Typical change in volume between matter phases. All materials undergo a change in volume as the material changes phases. Most materials increase in volume when the material melts, with water being the most substantial exception.

Melting

The PCM in contact with the container melts first, creating a fluid boundary between the solid PCM and the container. This fluid serves to transfer heat between the container and the remaining solid PCM. As the material expands, the fluid exerts a uniform pressure on the container.

Thermal Actuators

Generating Force

During the melting process, the liquid PCM exerts hydraulic pressure on its surroundings. With the exception of the height gradient, the pressure exerted is equal on all surfaces.

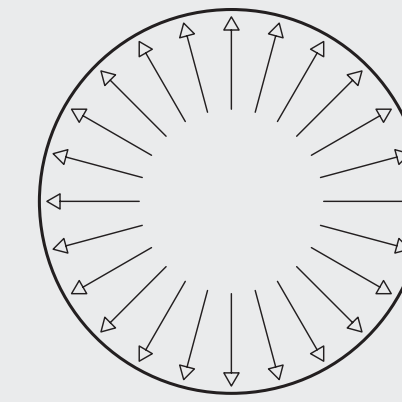

If the PCM is encased in a sufficiently strong material, the pressure generated by melting can be directed and controlled.

The pressure from melting can do mechanical work. This is the basis of all thermal actuators.

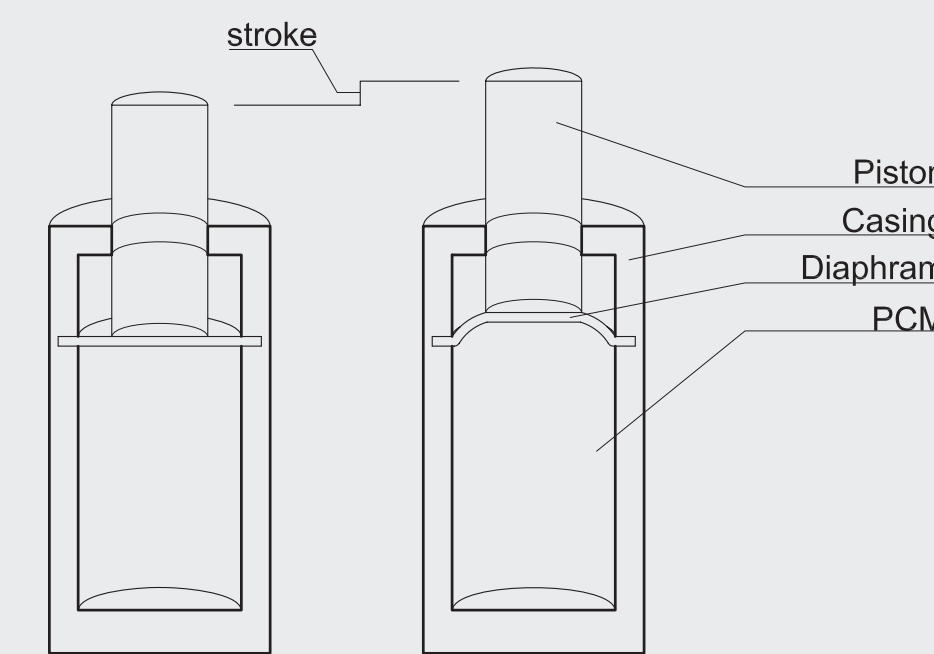

Displacement thermal actuators operate by converting the latent heat of phase change into mechanical energy. To drive the displacement, a phase change material (PCM) is chosen that exhibits favorable melting and freezing characteristics. These characteristics would include high volumetric displacement upon phase change, as well as a melting point at a chosen temperature threshold. The PCM melts as the threshold is crossed, which increases the volume of the PCM. When the PCM is enclosed in a sufficiently strong container, this volumetric expansion can be directed and controlled.

Heat Switches

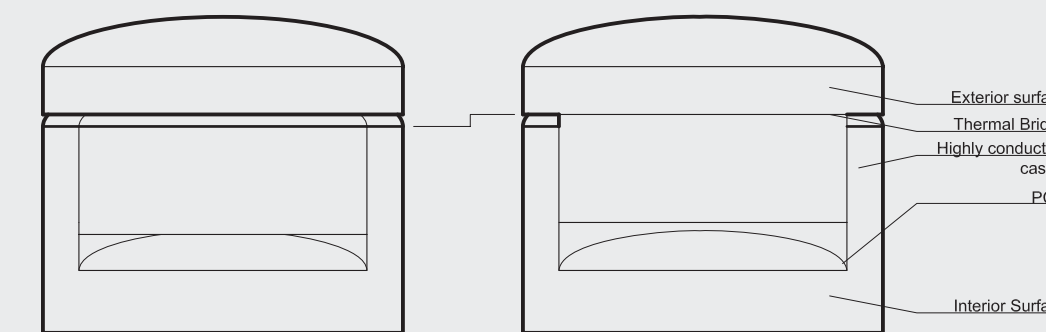

Heat switches work as operable thermal bridges. As the interior surface heats up, the PCM is melted, which moves the thermal bridge that conducts heat from the interior out to the exterior.



Spacecraft thermal control mechanisms often use heat switches

Fluid Displacement

Fluid Displacement Thermal Actuators are a class of thermal actuator defined by the use of a hydraulic Force Transfer Fluid (FTF) to transfer the displaced volume to a piston. Advantages over other thermal actuator designs include the ability to greatly magnify the piston displacement, as well as the ability of the PCM to be placed in a different environment to the Piston.

The direct nature of thermal actuators, which can be activated by changes in their environment, often allows for simpler mechanical feedback loops than can be offered by other systems. Electric systems require separate sensors and actuators, as well as an external power source to drive the system. Thermal actuators are most advantageous compared to electronic systems for thermodynamic regulation systems, where thermal actuators can draw their energy from the surroundings without the need for a controlled energy source. An inherent system integration, in which the actuator functions as the sensor and is capable of drawing energy directly from its surroundings, lends PCMs to be used in systems where maintenance is difficult or impossible.

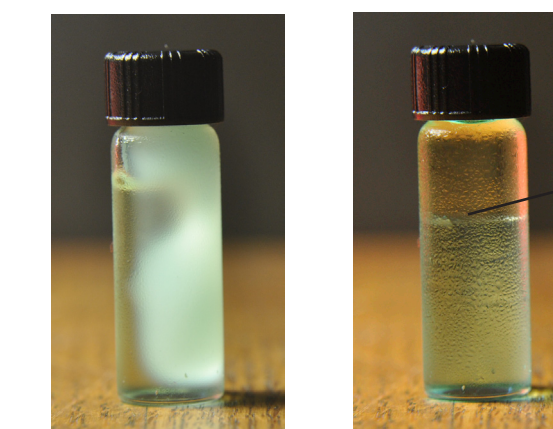
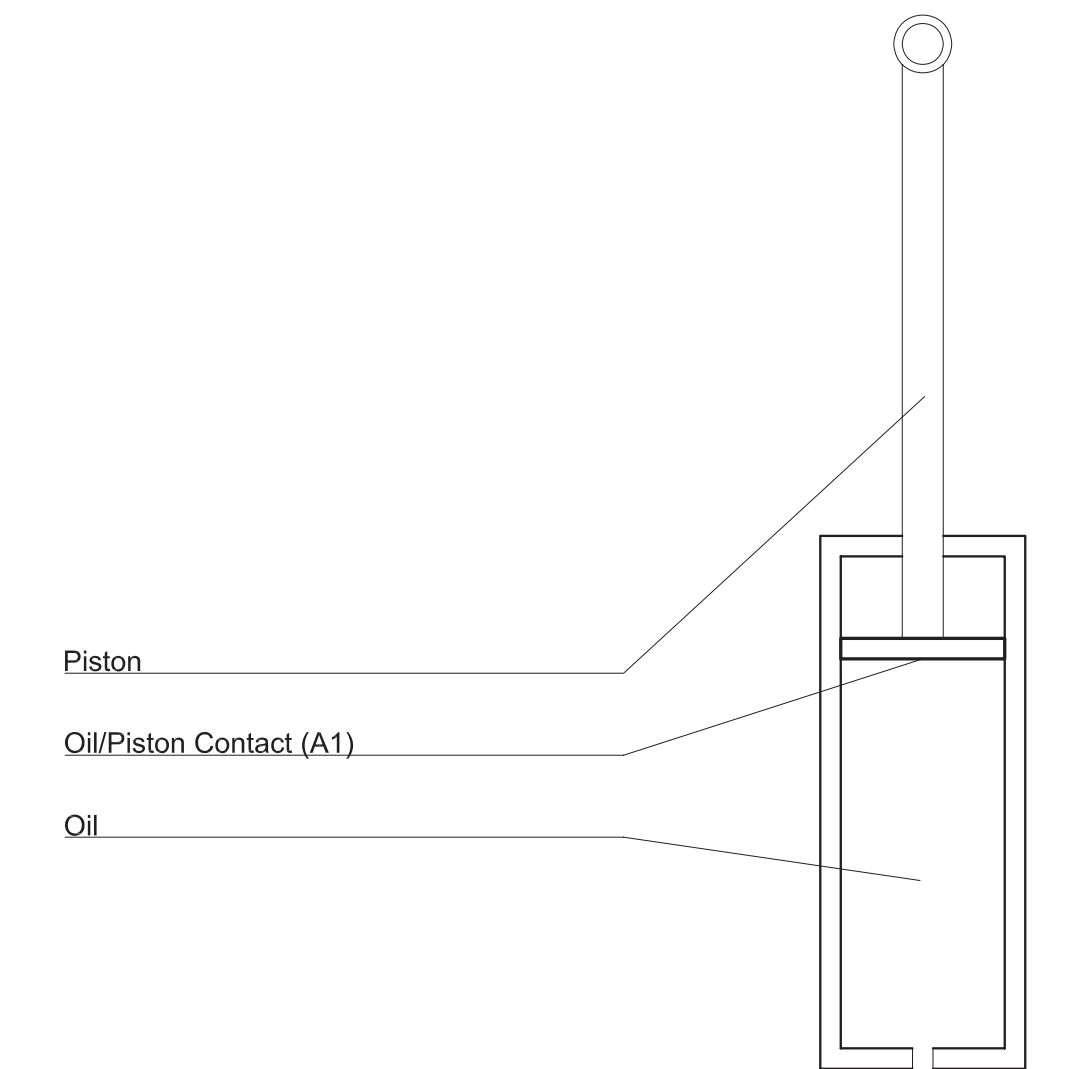

Meniscus

If the container is filled with a PCM and a non soluble liquid of a different density, the two materials will stratify.



PCM/Oil Contact (A2)

PCM

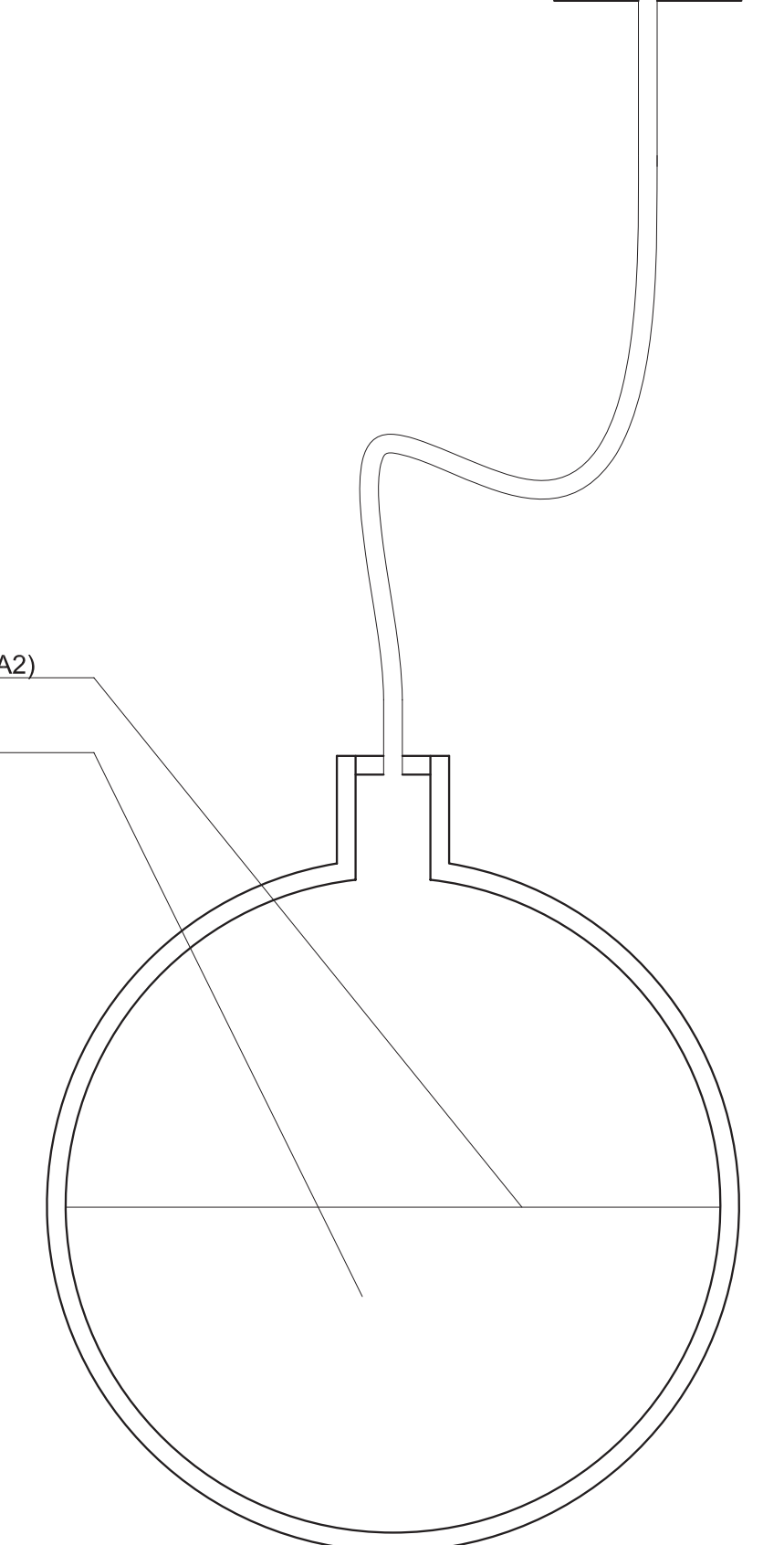

Principles & Physical Foundation

Ambient

Ambient actuators receive their energy from their surrounding environments. If the ambient temperature rises above the threshold temperature for long enough, the actuator will be activated.

Seasonal Actuation

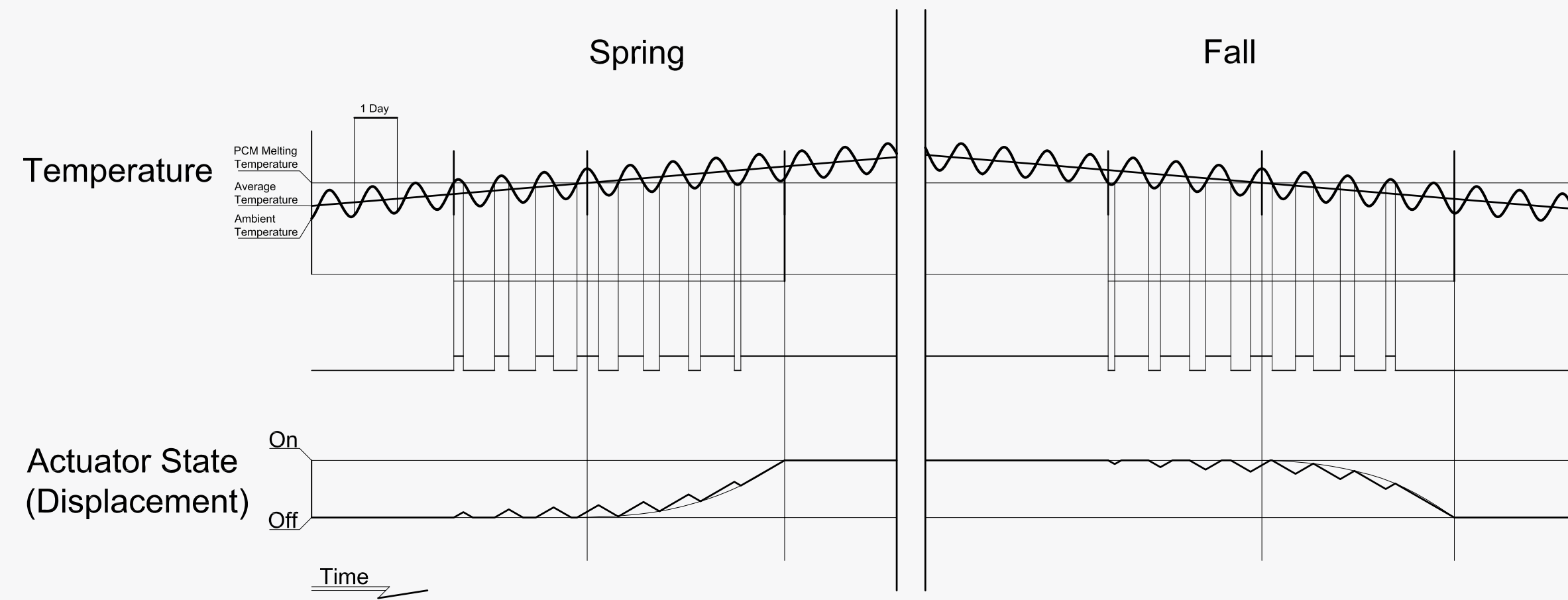

Ambient actuators can be designed to be activated by a number of different circumstances. The thermal flux and latent heat capacity determine the amount of time and energy required to activate the actuator. By designing for a high thermal flux, a low latent heat capacity, or both, the actuator can function in a diurnal role during specific seasons. If the actuator is designed with a low thermal flux, a high latent heat capacity, or both, the actuator can function on a seasonal basis.

Diurnal Actuation

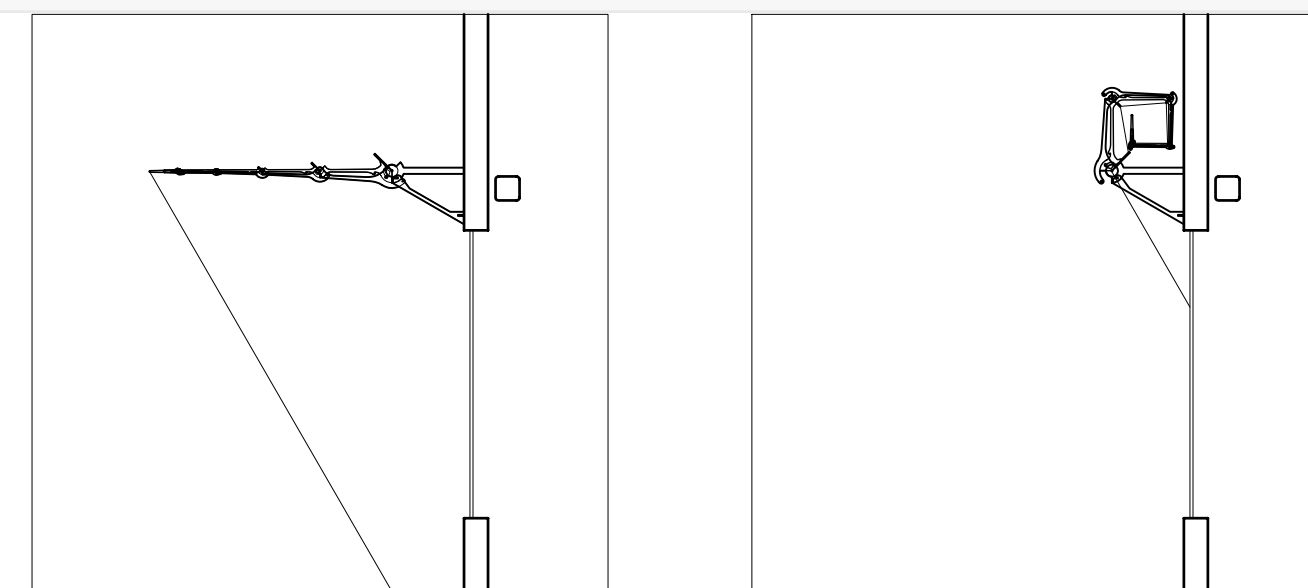
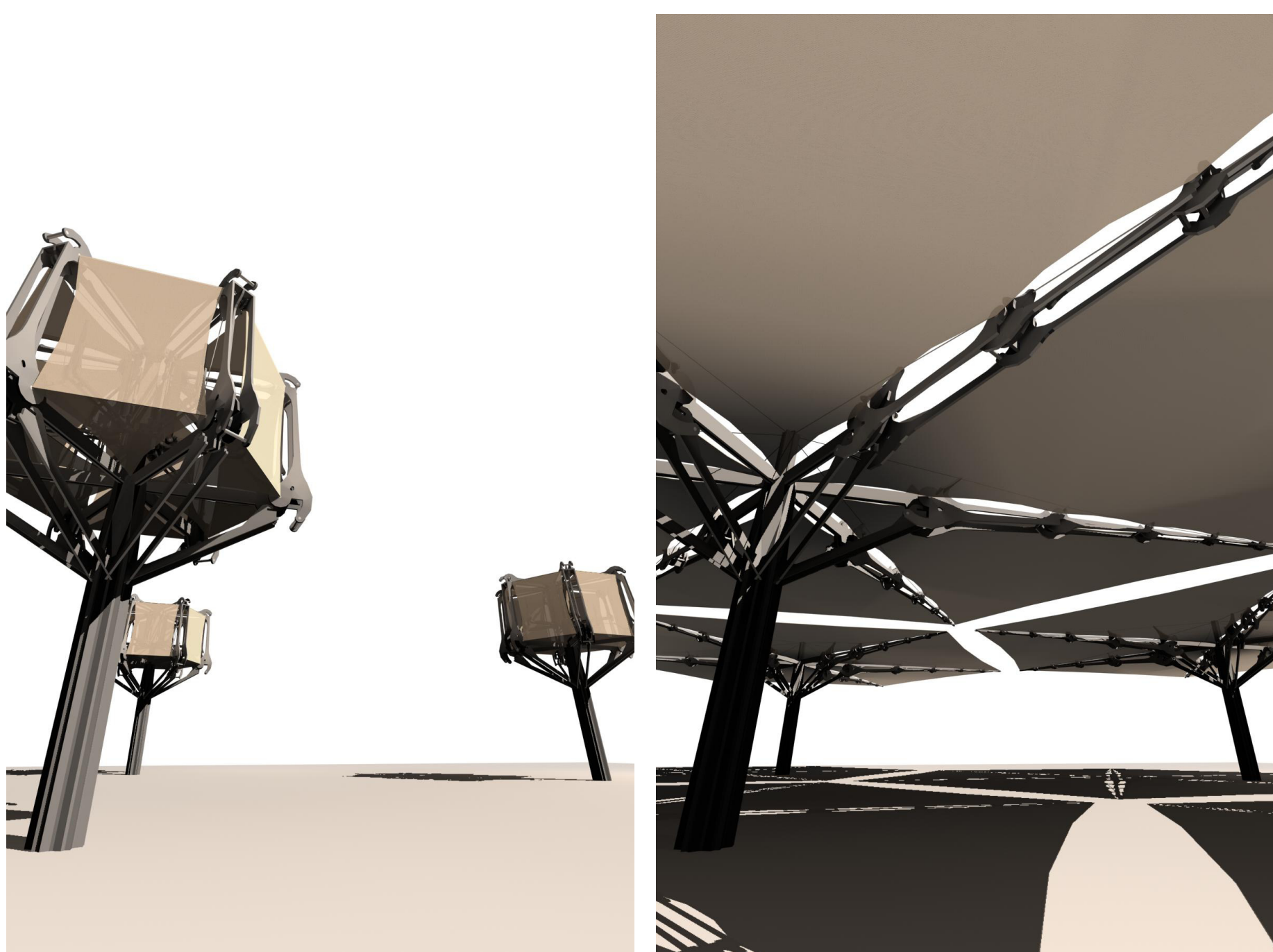
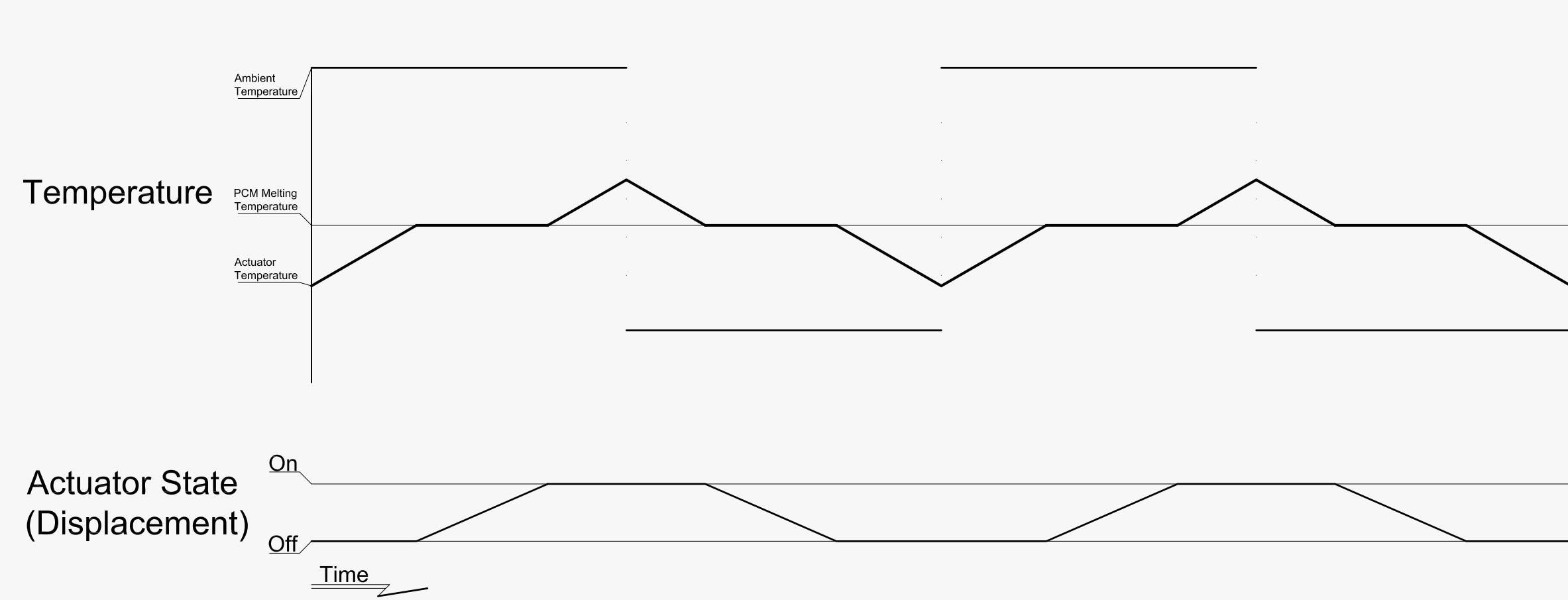

If the PCM is placed inside of the conditioned space, the shading device will only deploy if the interior temperature rises above the melting threshold.

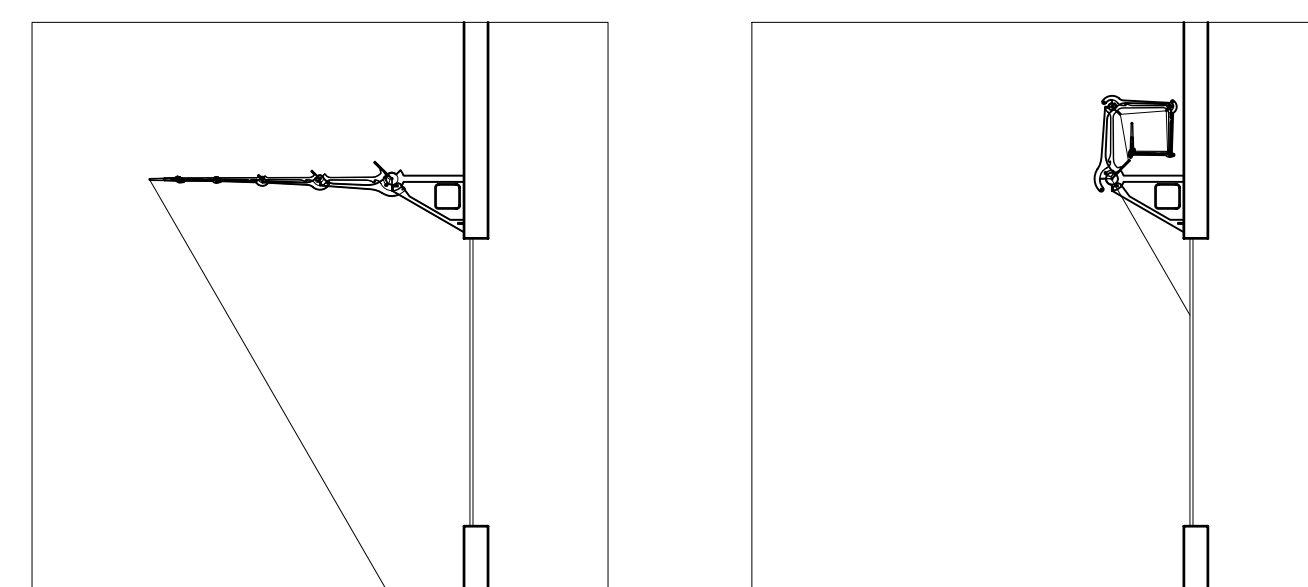

If the PCM is placed in the exterior environment, the shading device will deploy whenever the ambient temperature rises above the melting threshold.

Solar

Solar actuators are distinguished from ambient actuators by their use of solar energy for actuation. By using the sun's energy, solar actuators can activate even when the ambient temperature is below the temperature threshold.

Solar actuators are particularly advantageous because of the high levels of energy that can be absorbed directly from the sun. This efficient use of energy may translate to latent heat engines, depending on the thermodynamic reversibility of the process.

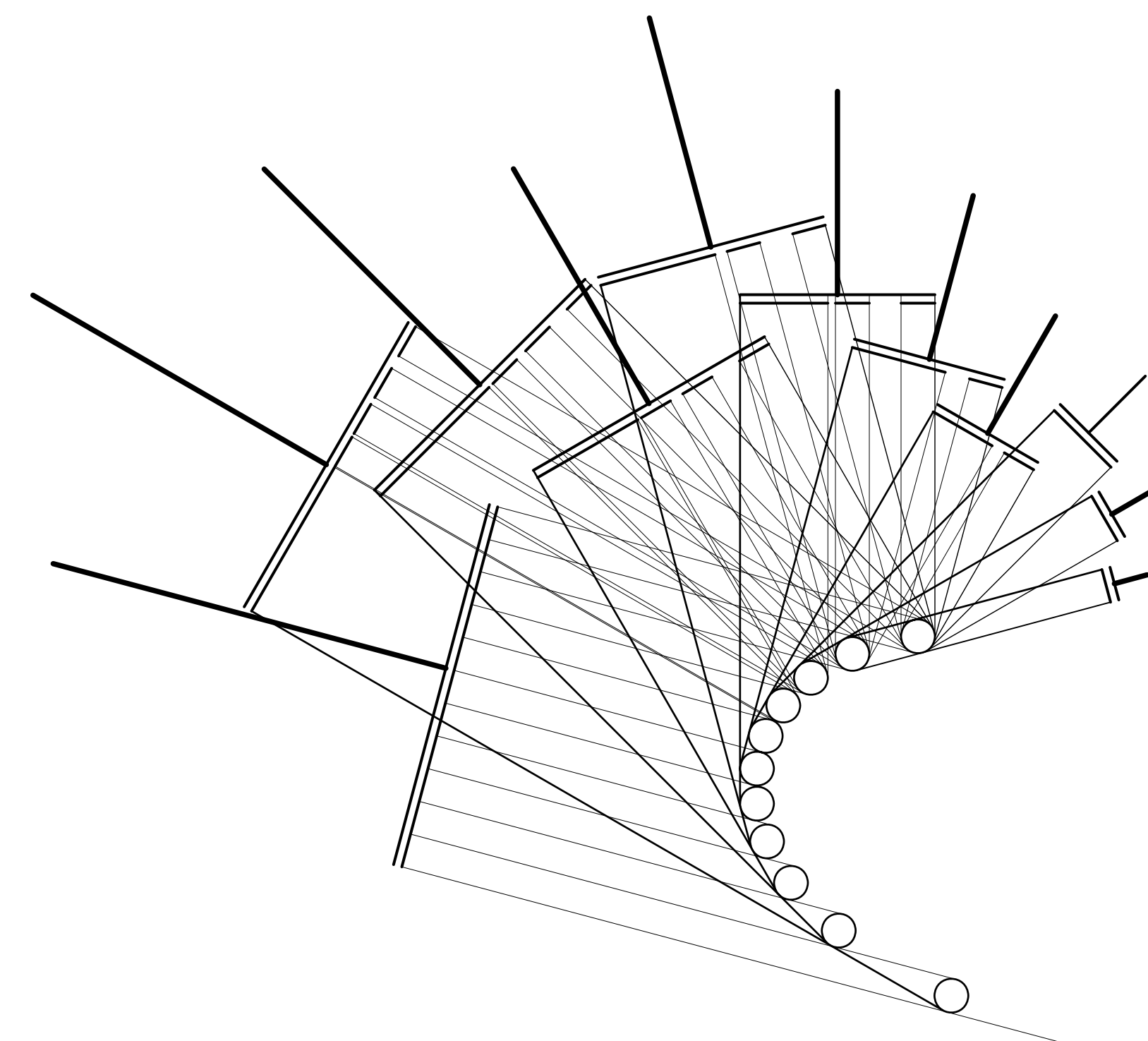

This design for a solar array works as a cumulative sundial. As the sun passes from east to west, the number of cylinders with solar access increases.

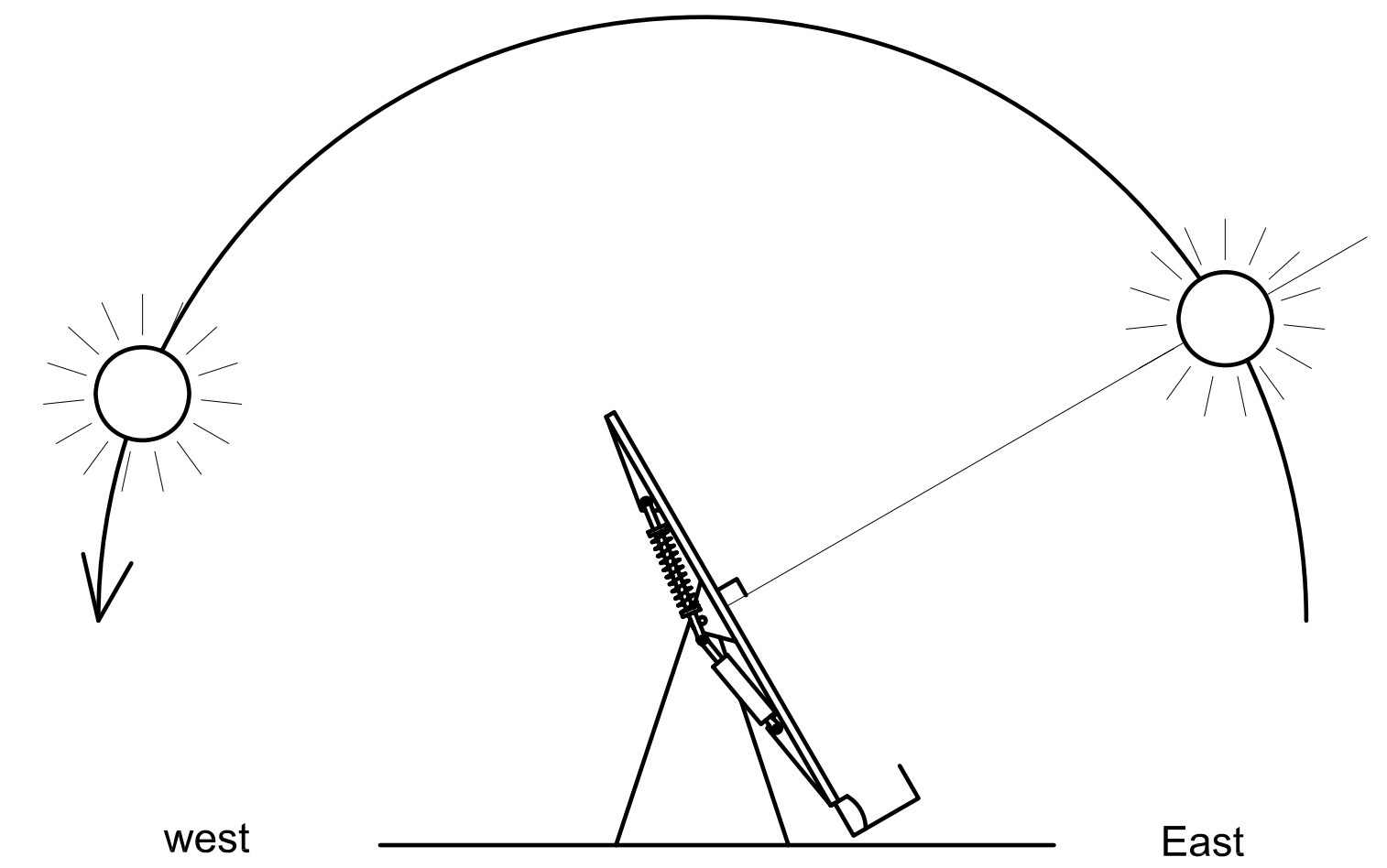

As the sun rises in the east, the solar actuator waits to activate until the sun hits the cylinder.

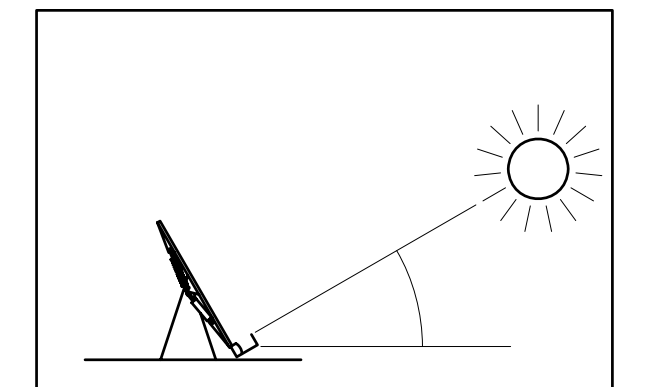

As the sun strikes the thermal actuator, it warms the cylinder, creating a force that rotates the array to face the sun.

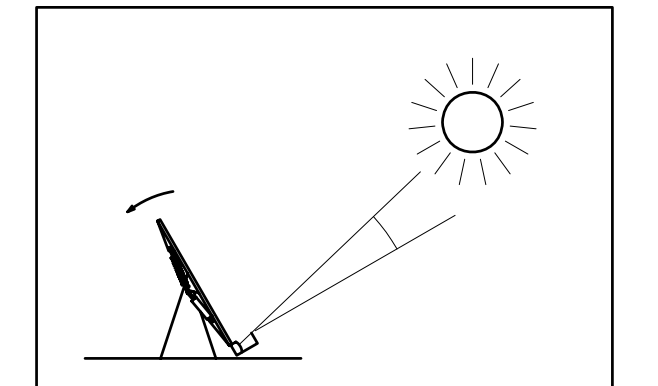

After the array has rotated past the sun, the cylinder will cool down and begin to track back towards the east. If the array rotates to far, it will activate the cylinder again.

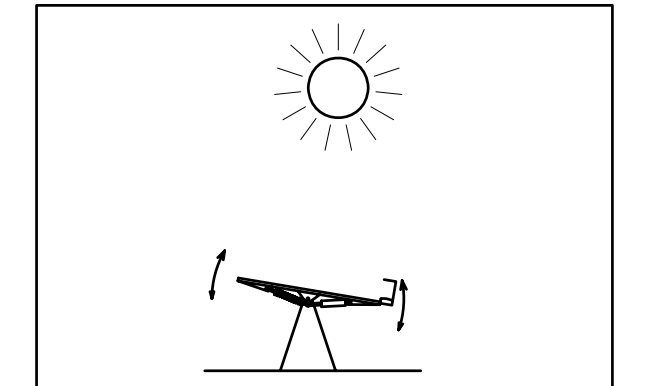

After the sun sets, the cylinder cools down and returns the array back to face the east.

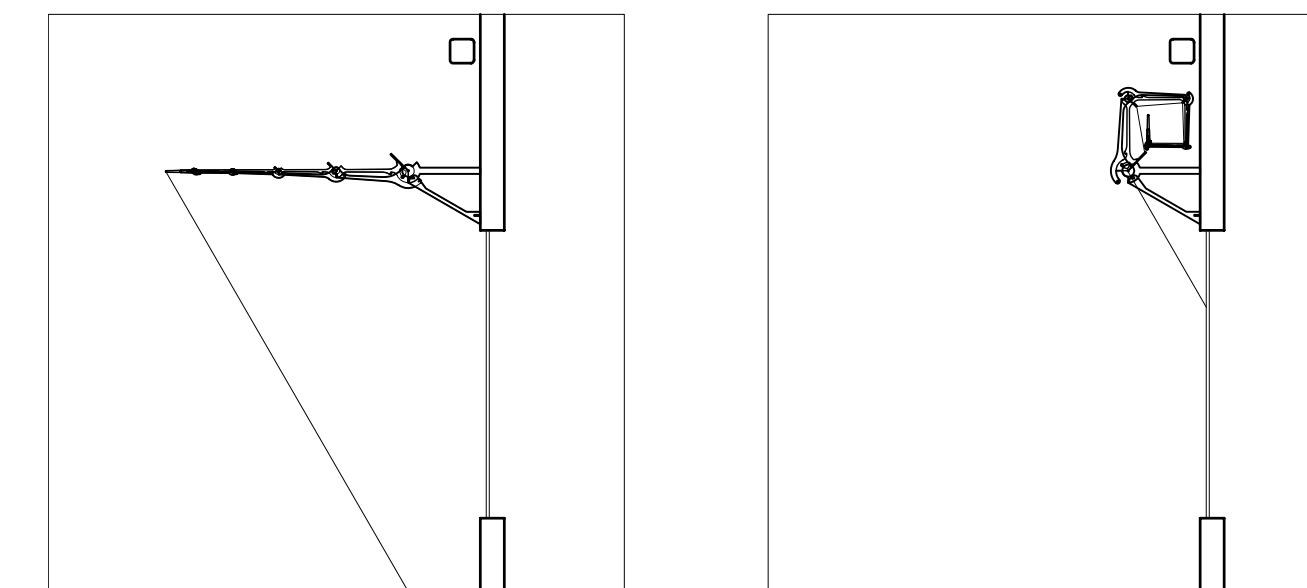
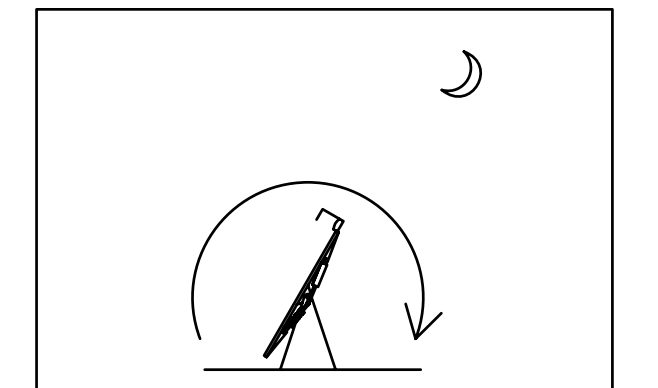

In a standard solar shading device, the shading device is coupled to the amount of solar energy striking the actuator.

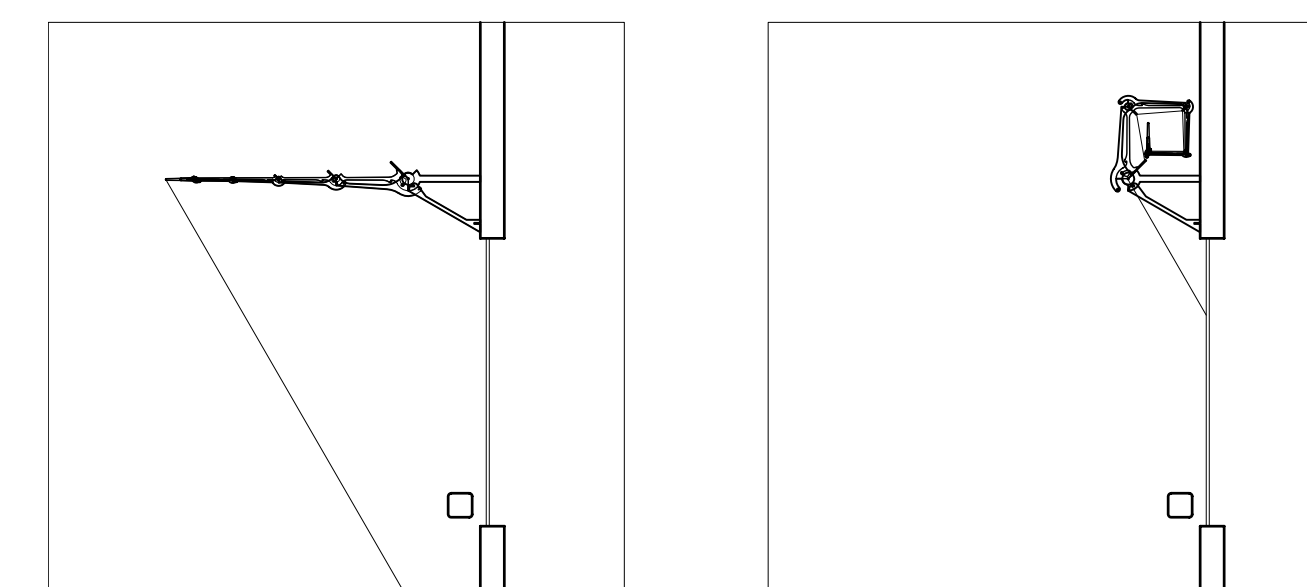

In a self shading design, the actuator absorbs energy until it expands, protecting itself from further thermal gains.

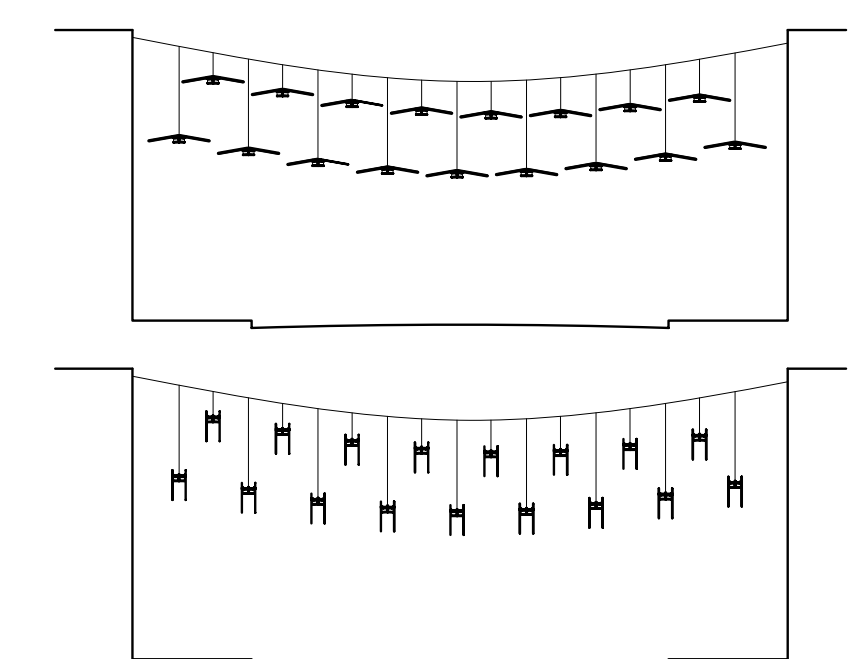
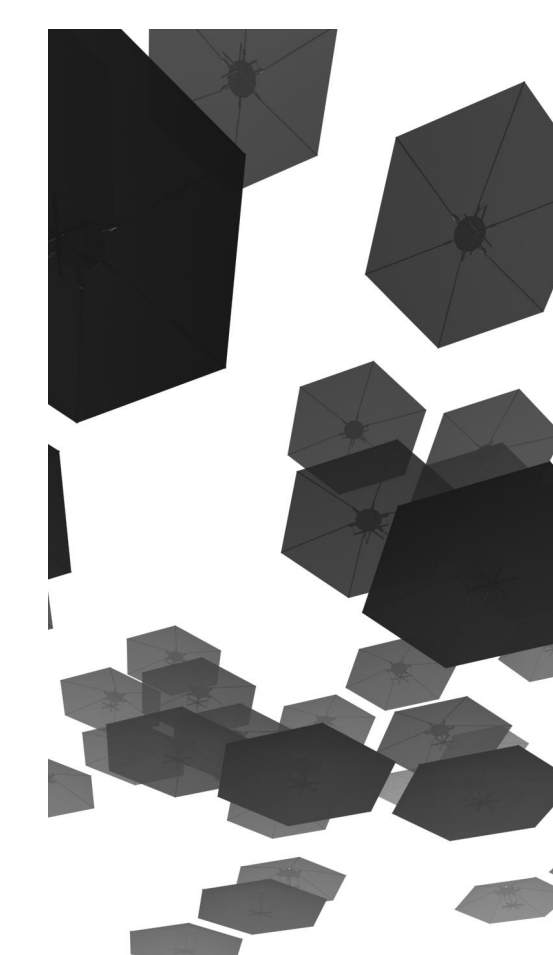

Container Thermodynamics

The flow of heat through the enclosure, as well as through the PCM, determine how quickly the thermal actuator will react to its environment.

Thermal Conductivity
Materials with high conductivities will transfer heat faster than materials with lower conductivities.

$$U = \frac{k}{\Delta x}$$

U = Thermal Conductivity (W/m K)
k = Material Conductivity
x = Distance of Conduction

Material	U value (W/m K)
Acrylic	0.2
Aluminum (6061-0)	180
Brass	125
Cast Iron	55
Copper (C10200)	391
Glass	0.8
Steel	50
Paraffin (Solid)	0.24
Paraffin (Liquid)	0.24
Polyethylene Glycol	0.29

Thermal Flux

$$H = \frac{\Delta Q}{\Delta t} = k \times A \times \frac{\Delta T}{x}$$

There are several methods for increasing the energy flux through of the container.

H=Heat Conduction
Q=Energy
t=Time
k=material conductivity
A=Surface area
T=Temperature
x=Material thickness

Material Thickness



Greater thickness = smaller heat transfer rate

Smaller thickness = greater heat transfer rate

The thickness of the material is inversely proportional to the rate at which heat is transferred through it. Thicker materials, therefore, transfer heat slower than thin materials. The thickness of the material should therefore be as thin as possible to facilitate heat transfer while still resisting the pressure imposed on the container.

Temperature Differential

A greater difference between the exterior and interior will facilitate higher rates of energy flow.

Surface Area

Increasing the surface area to volume ratio will increase the rate of energy flow into the container.

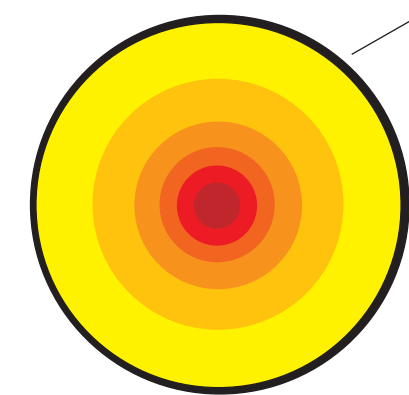

Phase Change materials melt and freeze in concentric rings based on how far the material is from its container.

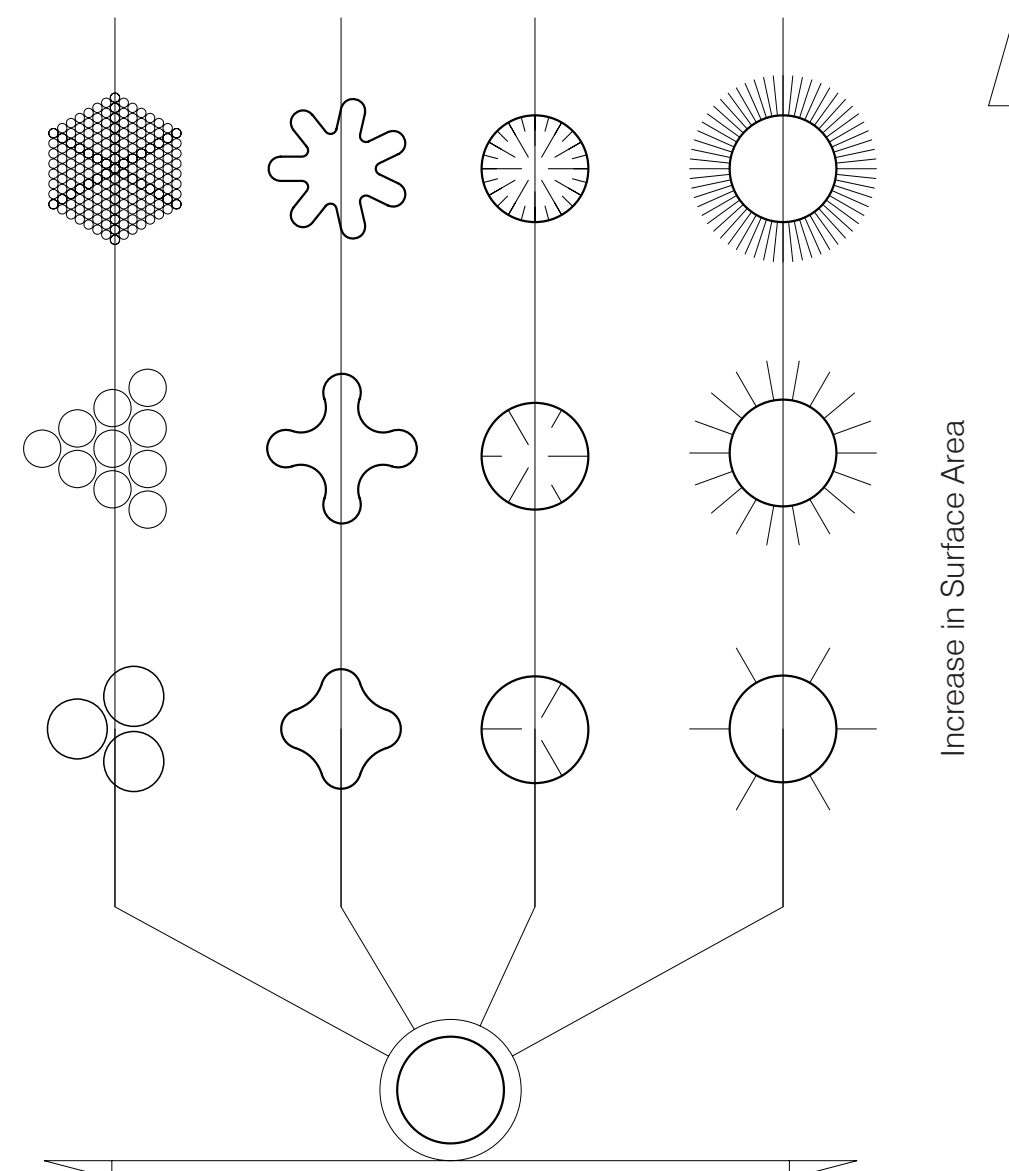

Membrane Strategy

Single Membrane

In a single membrane container, the PCM is set between the container wall and a flexible membrane. This container design allows for a very large, relatively flat external container. The life of the actuator would likely be determined by the membrane's ability to survive through repeated flexing.

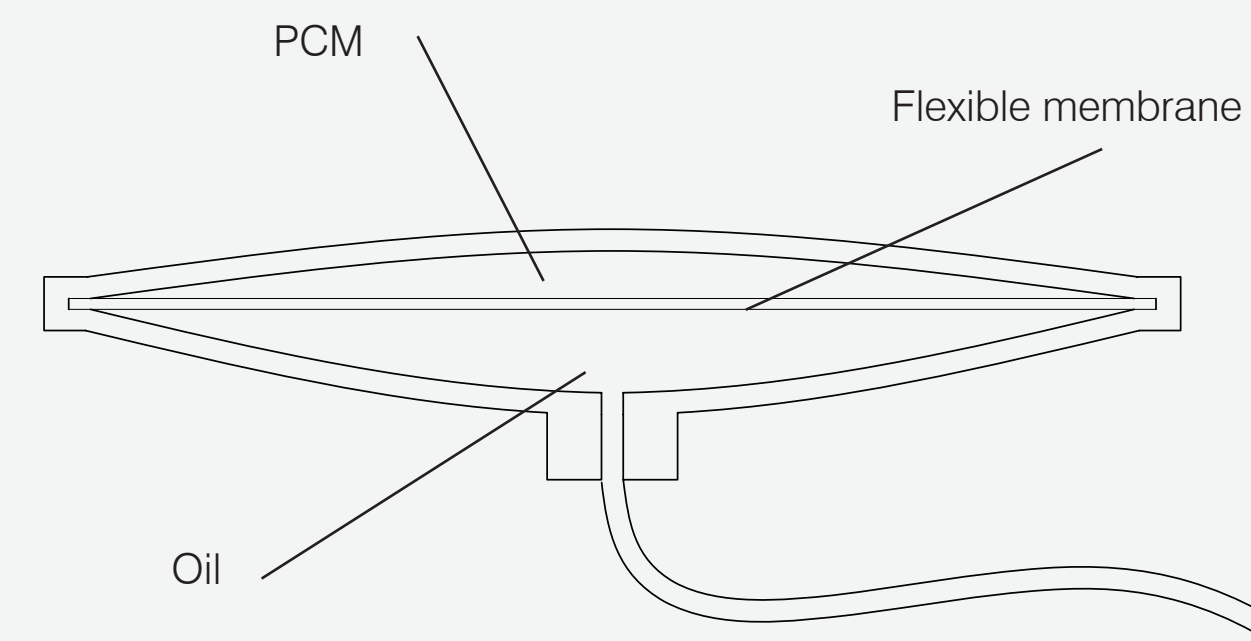

Spherical Membrane

If the PCM is completely contained inside a flexible membrane, the PCM can be easily stored, transported, and used. The life of the actuator would be determined by the container's ability to survive many expansion cycles. The thermal conductivity of the PCM container would be determined by the size of the sphere, with smaller spheres having a larger surface area in relation to the overall volume of PCM required.

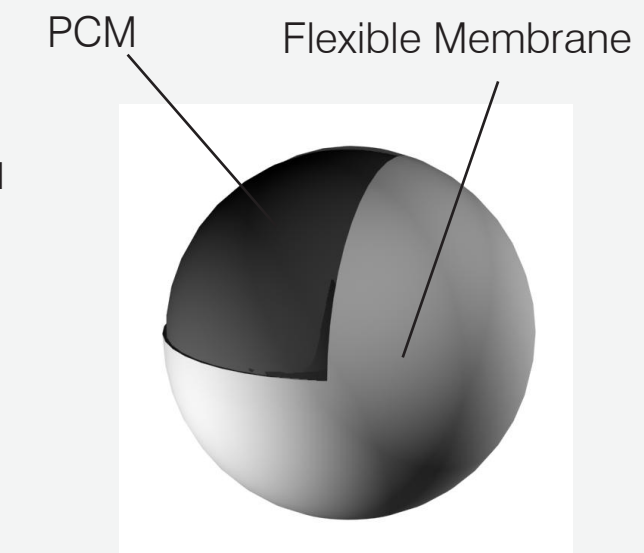
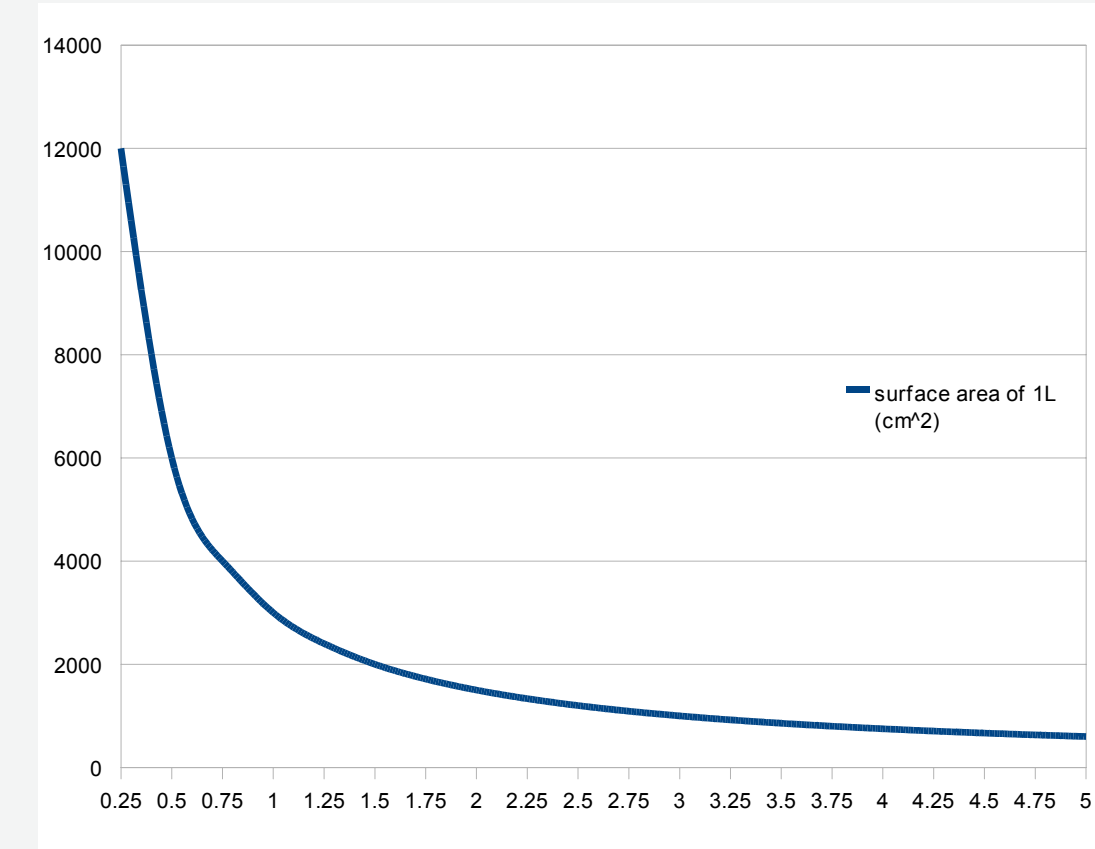

Spherical PCM Pellets work directly in the hydraulic fluid

No Membrane

Thermal actuators can be designed without membranes if the PCM and the oil can maintain a meniscus and avoid chemical degradation. This may lead to more reliable thermal actuators, as the membrane is the most common point of failure in existing thermal actuator designs.

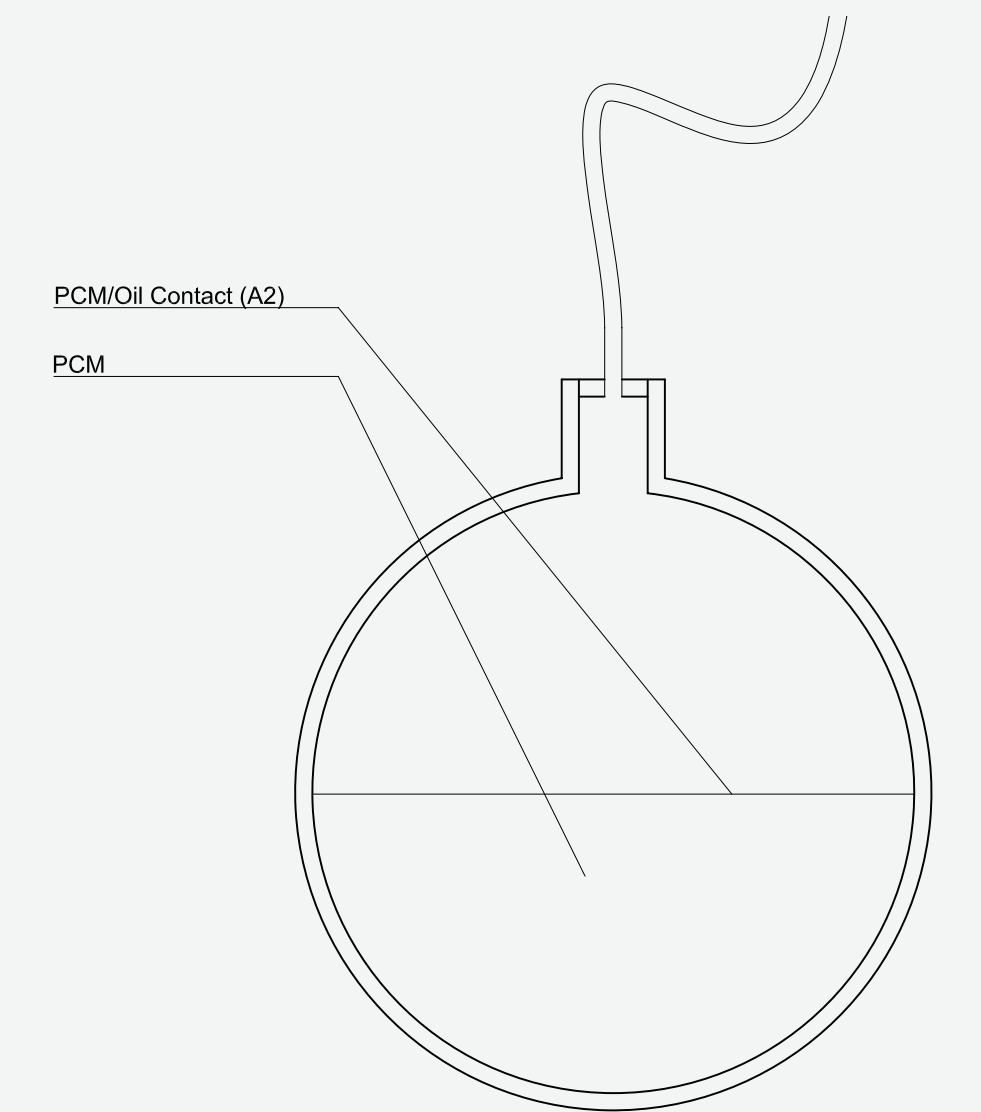

Design exercise - extrusion

The balance between structural and thermodynamic considerations often leads in opposite directions. Structurally, spherical and cylindrical containers offer the highest resistance to pressure using the least amount of material. Thermodynamically, the surface area of the container, as well as the distance of the PCM from the container walls leads to structurally inefficient designs. Extruded heat fins can be used to increase surface area, as well as provide local stiffening.

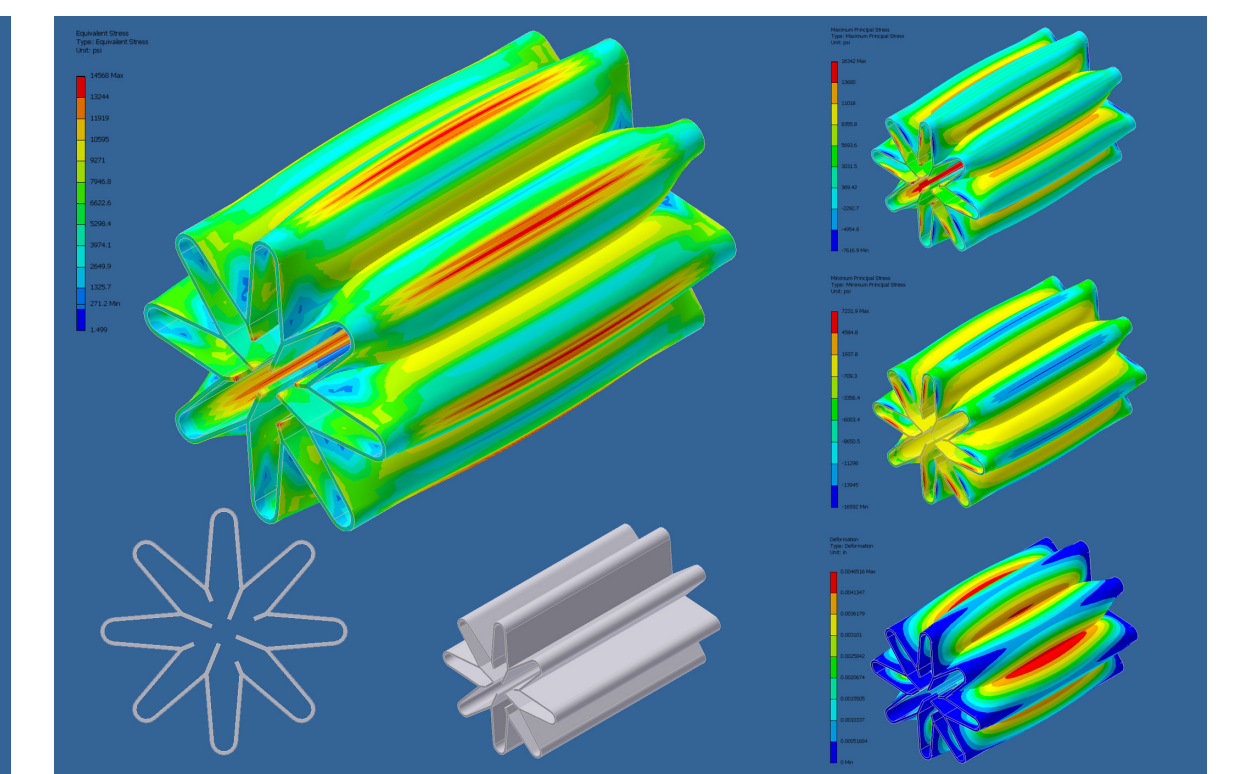
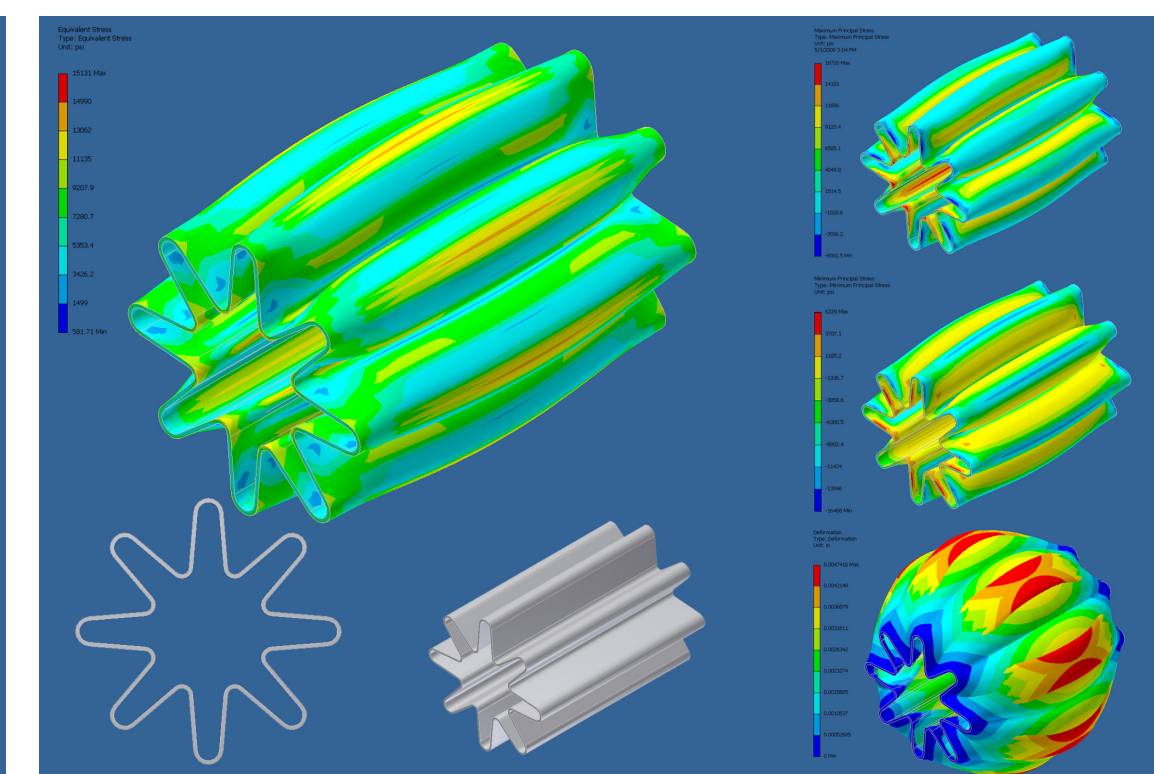
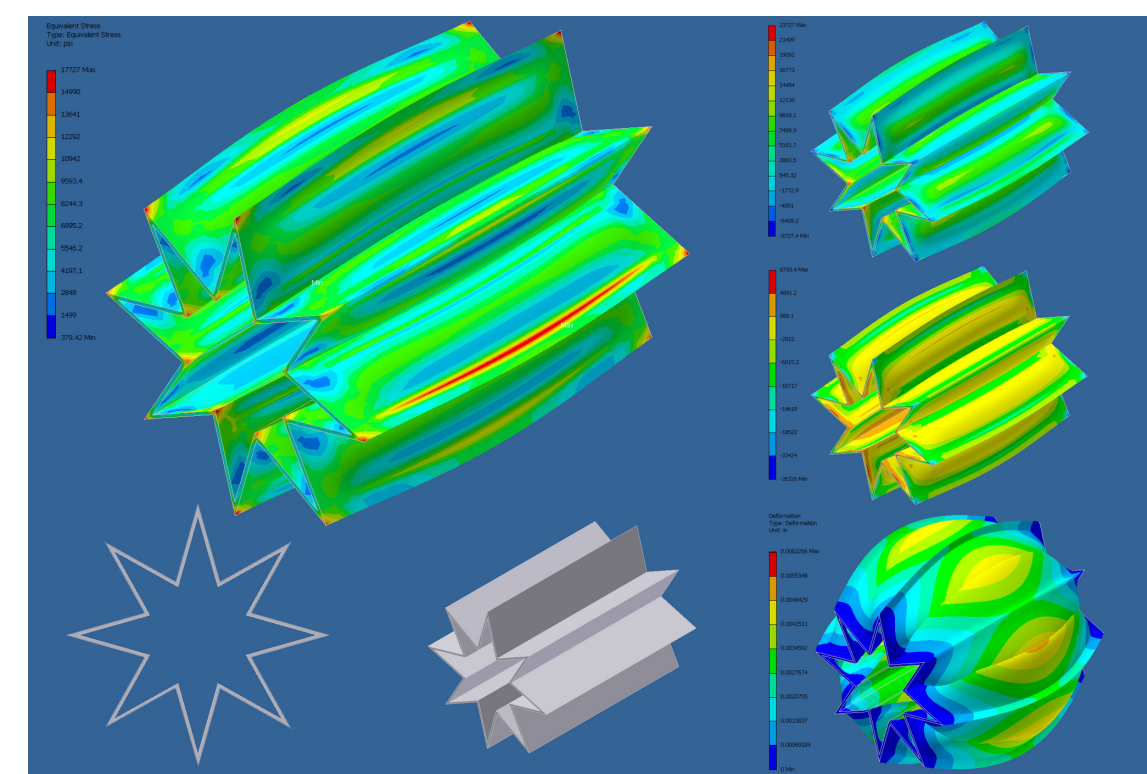
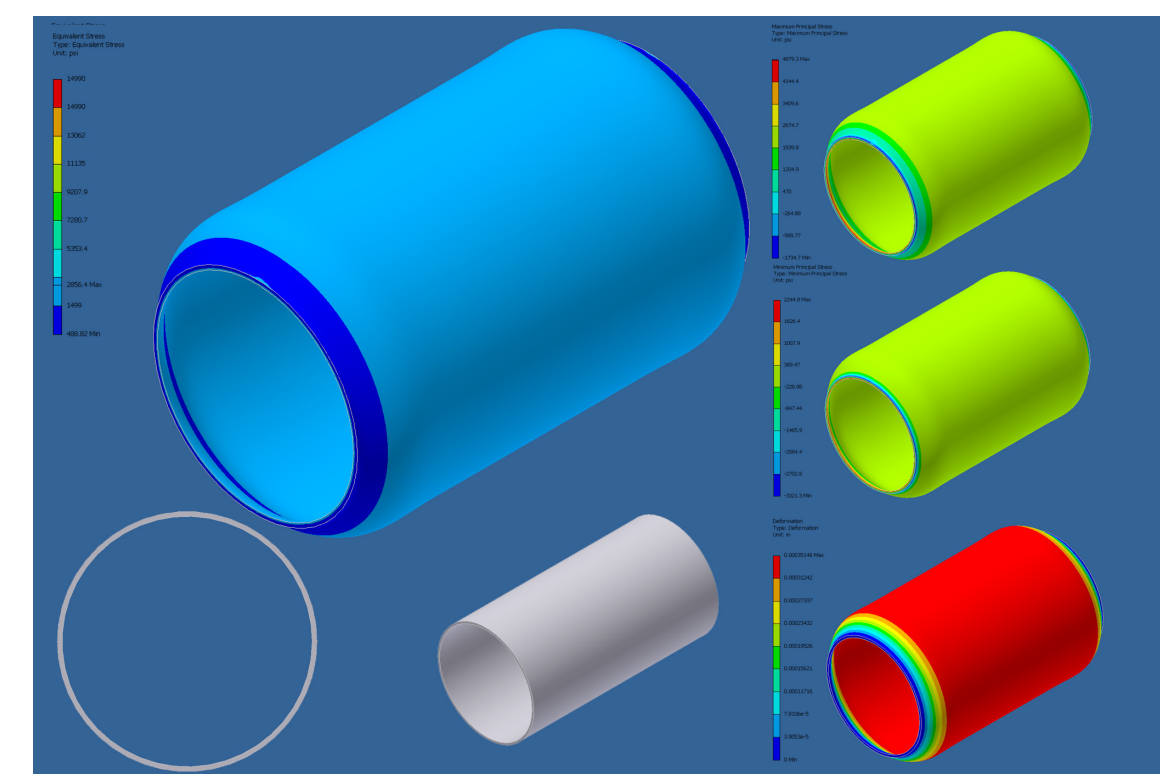
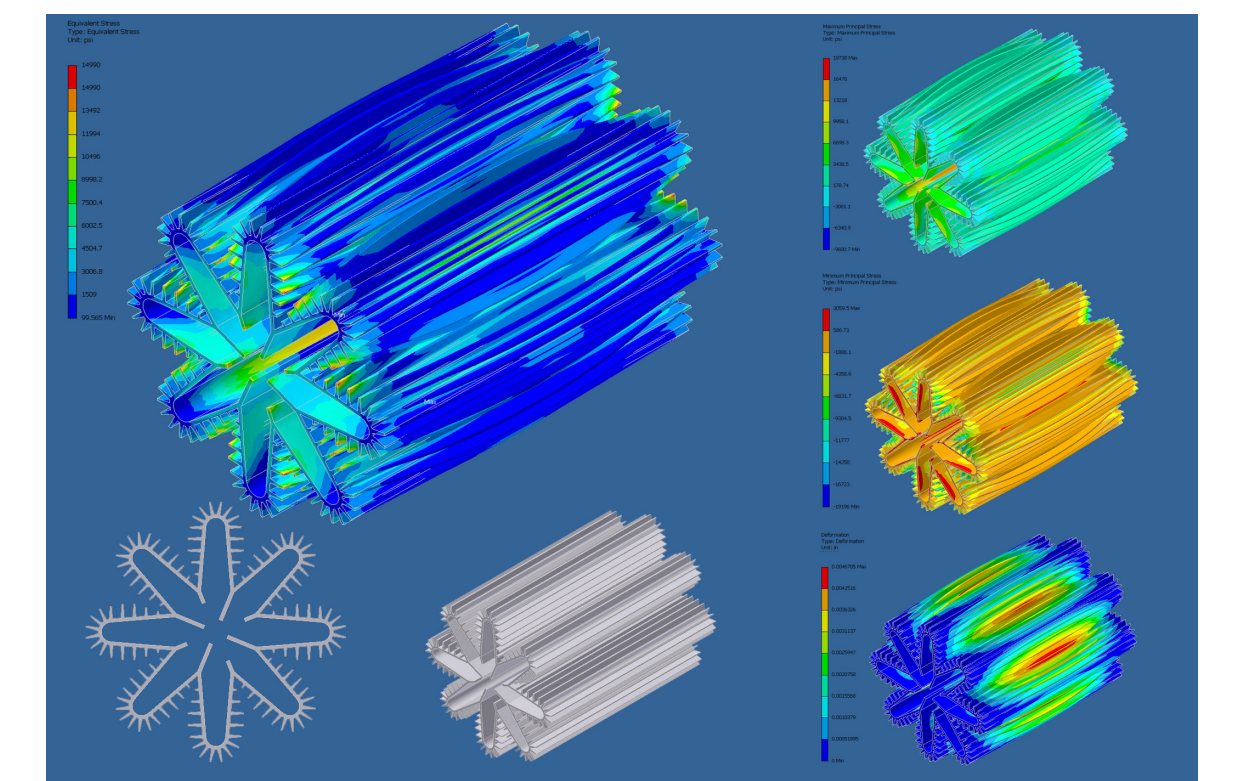
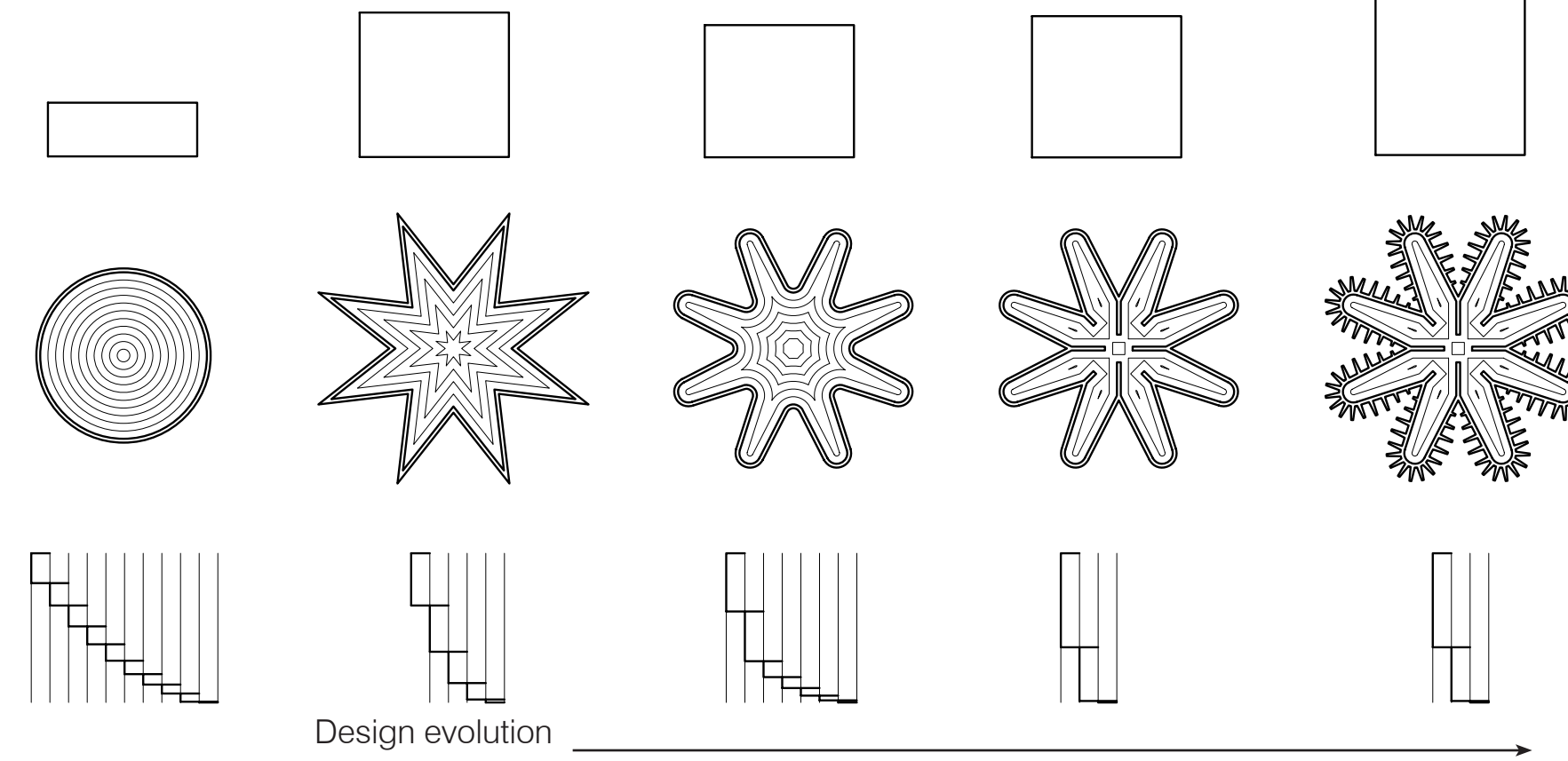

Actuator Container Design

Movement

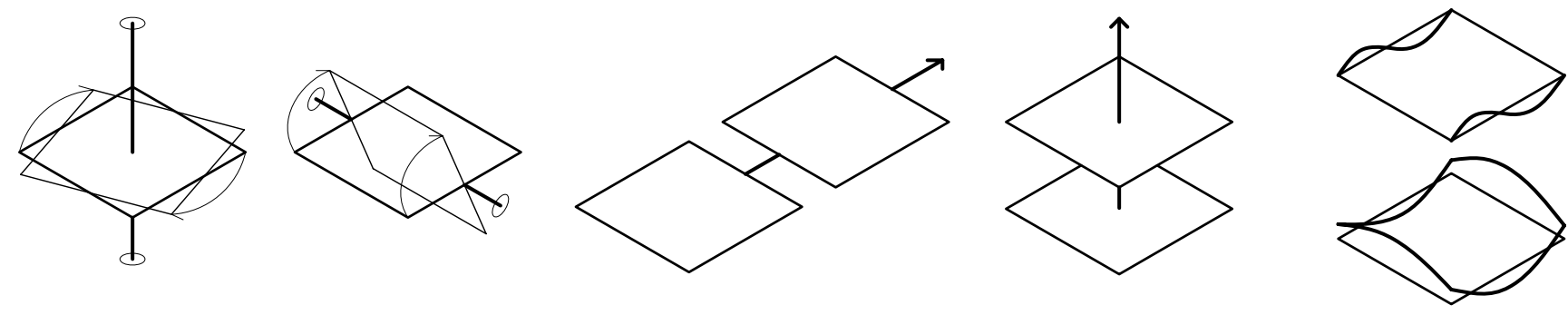

Thermal actuators can be used to create rotation, translation, and flexure.

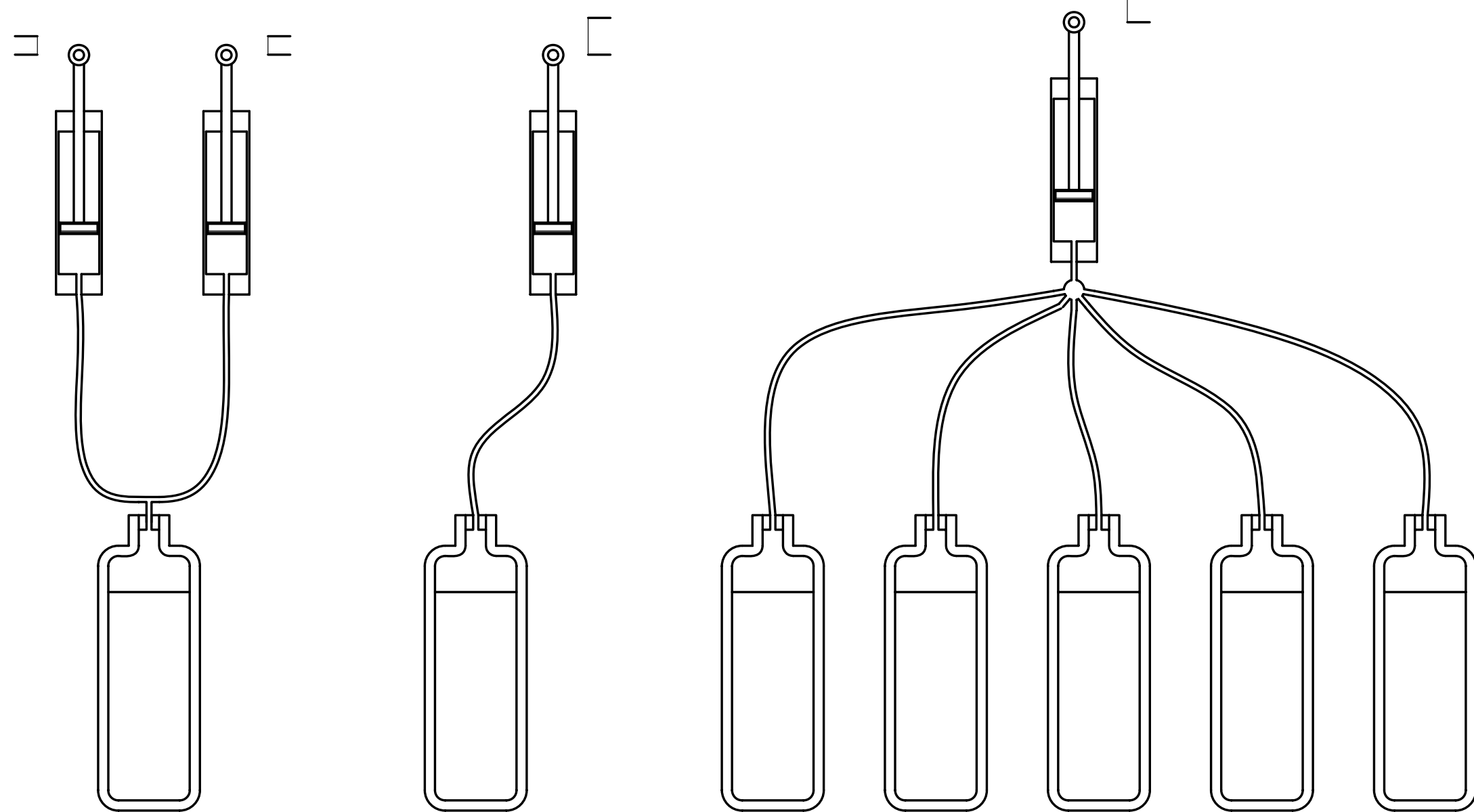

Multiple containers can be used to actuate a single piston. This allows for multiple stages of actuation, creating a highly controlled movement.

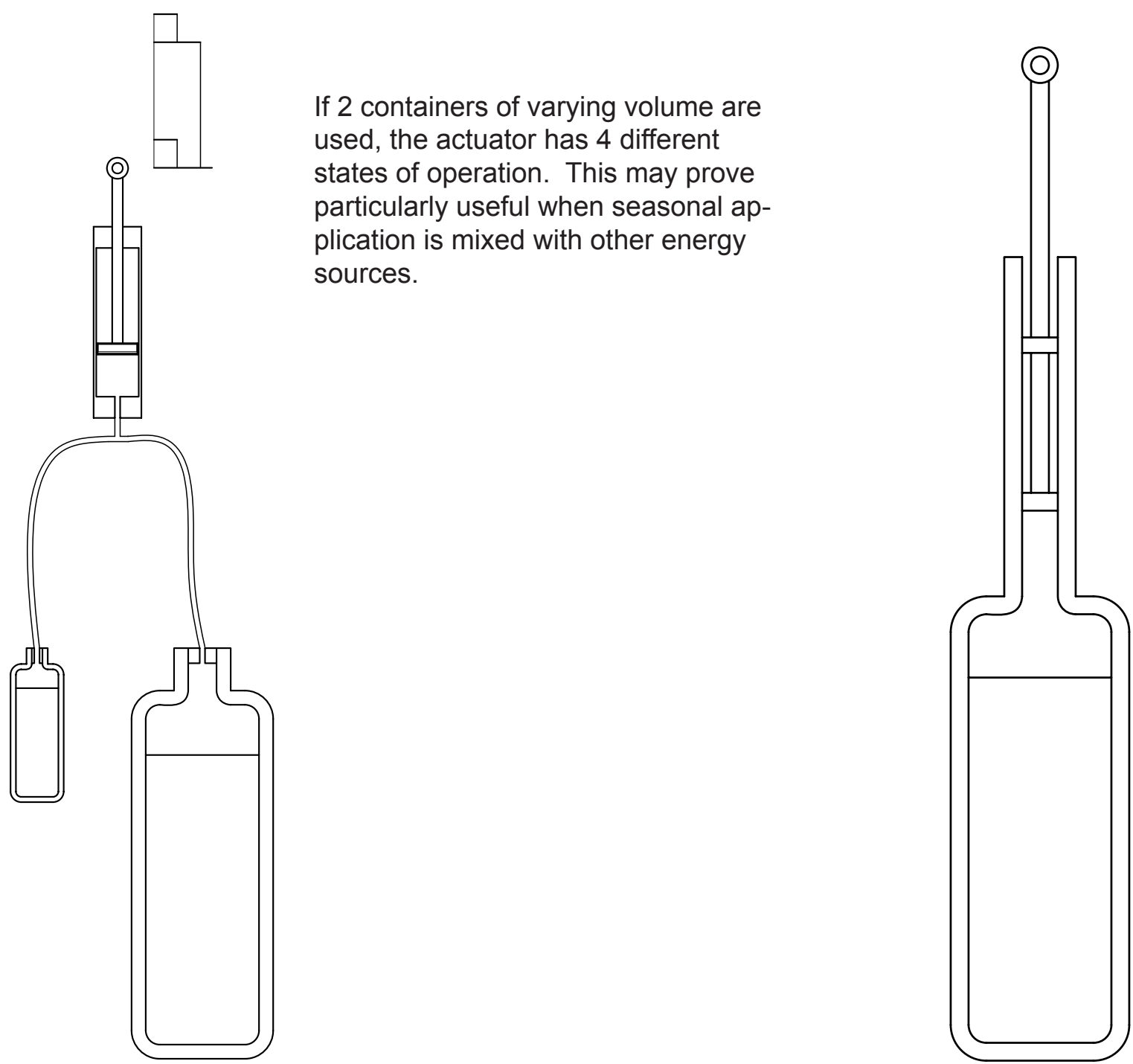

If 2 containers of varying volume are used, the actuator has 4 different states of operation. This may prove particularly useful when seasonal application is mixed with other energy sources.

The piston and PCM volume can be incorporated into a single container.

Iterative Sequencing - Rotation

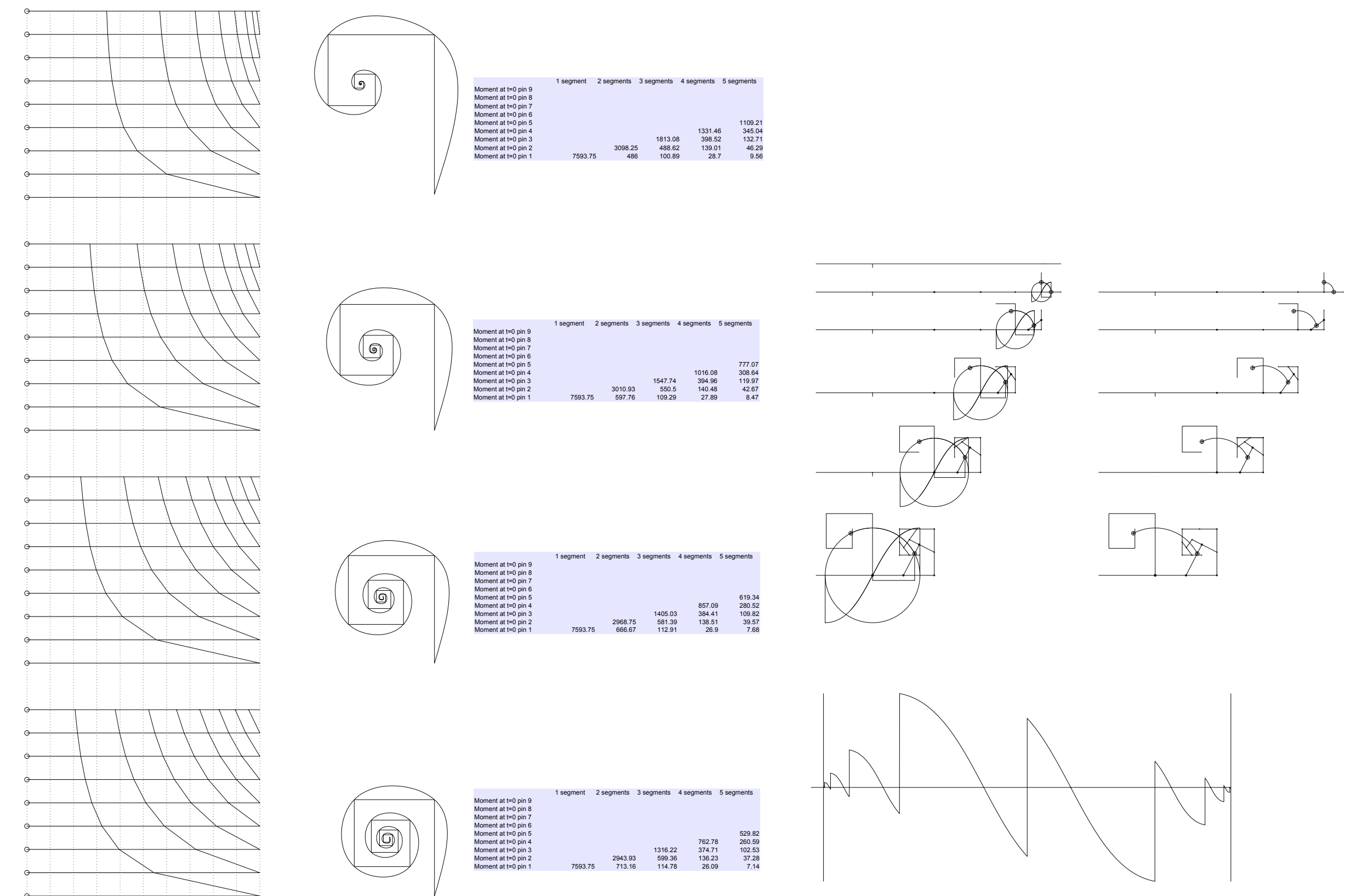

The harmonic ratio that governs the length of the arm segments determines the overall form of the contracted arm. Smaller ratios generate a tighter spiral in which the arm length decreases faster than that of a spiral of a larger ratio.

If rotation is perpendicular to gravity, the force required to move each segment can be mapped out in an iterative algorithm. More arm segments translates to a lower force required.

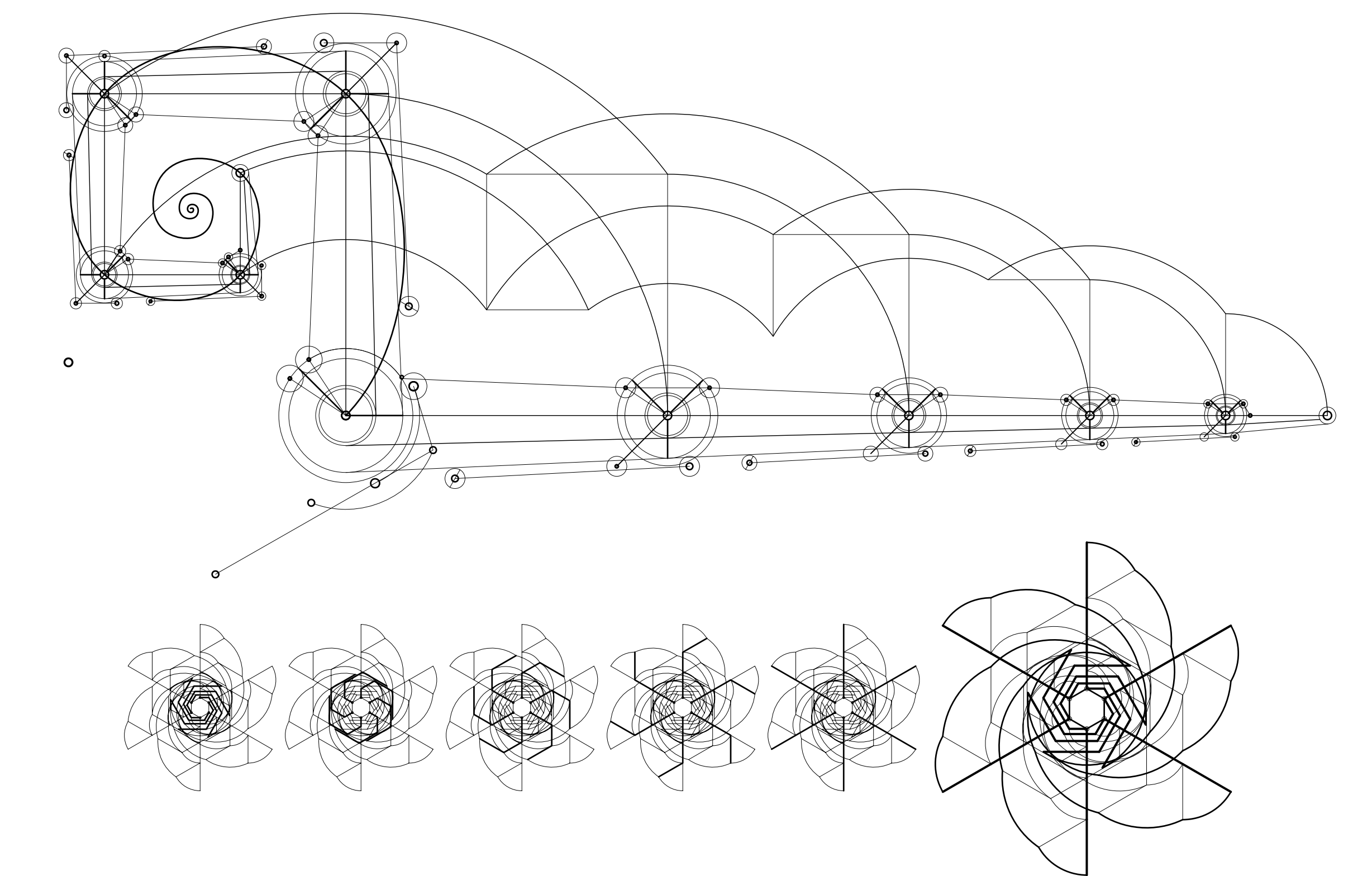

Boolean Logic

Boolean logic creates an algebraic system for logic. Boolean logic is different from traditional set logics in that it requires all sets to be reduced to two states. This binary operation formed the foundation of modern computers, and all computers operate as electrical boolean circuits. Boolean Logic is particularly applicable to thermal actuators because each actuator can be treated as a switch with two possible positions.

In order to accommodate for a thermal comfort zone, a simple matrix can be devised that has a total of four binary inputs. The first two columns of the matrix divide between environments, with the first column being outside of the building envelope, and the second column being inside the building envelope. Each of these categories is divided into the thermal thresholds at which a control action can be taken. For the purpose of thermal comfort, these are defined as being 70 and 80 degrees Fahrenheit. Each of the possible permutations is assigned a thermal actuator.

- Actuator 1: activated when exterior temperature exceeds 70F
 - Actuator 2: activated when exterior temperature exceeds 80F
 - Actuator 3: activated when interior temperature exceeds 70F
 - Actuator 4: activated when interior temperature exceeds 80F
- The end result of the logic gate series would be the thermal separation of Exterior from interior environments. A value of 1 would translate to higher thermal conductivity or ventilation, while a value of 0 translates to a higher insulation, or thermal separation.

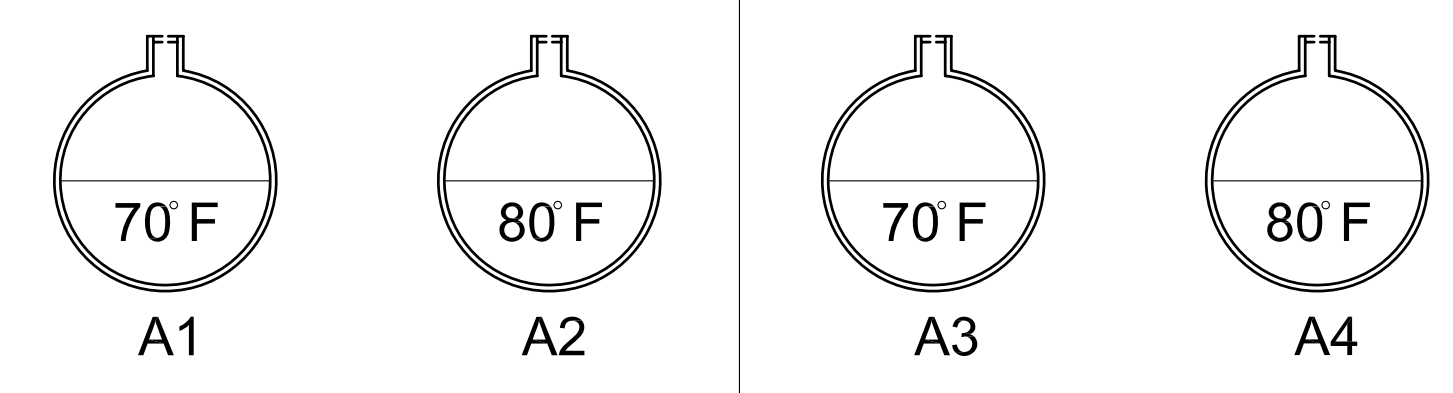

	a1	a2	a3	a4	e	
	0	0	0	0	0	0
	0	0	0	1	X	
	0	0	1	0	1	
	0	0	1	1	1	
	0	1	0	0	X	
	0	1	0	1	X	
	0	1	1	0	X	
	0	1	1	1	X	
	1	0	0	0	0	
	1	0	0	1	X	
	1	0	1	0	1	
	1	0	1	1	0	
	1	1	0	0	1	
	1	1	0	1	X	
	1	1	1	0	1	
	1	1	1	1	0	

	Hi, Ho	Ni, No	Hi, Co	Hi, No	Ni, No	Co, Ni	Co, Co	Co, Co
A1	1	1	0	1	1	0	1	1
A2	1	0	0	1	0	1	0	0
A3	1	1	1	1	1	0	0	0
A4	1	1	1	0	0	0	0	0
E	0	0	1	1	1	1	1	0

	Inside
Hi	1
Ni	0
Co	1
No	0

The logic gates can be designed as mechanical devices, allowing for the design of mechanical calculators. These systems can function as control centers that regulate various effectors.

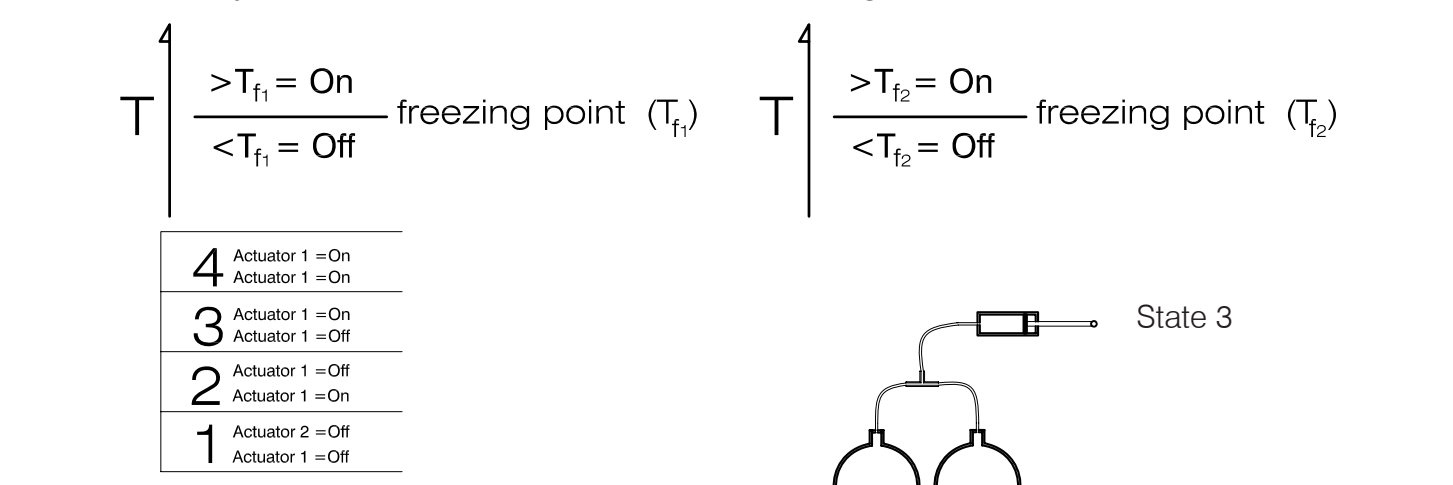

Two actuators can be linked together such that their displacement is cumulative. This can either create 3 or 4 total possibilities for the system, depending on whether or not the actuators have the same temperature of fusion, and if they are both placed in the same environment.



If two thermal actuators are operating in the same environment, the system can be designed such that the actuator with the lowest temperature of fusion will melt first and freeze last. This predictability can be used to simplify the total options for the system.

Thermal Parasol

The thermal parasol is a simple shading device that can be hung from above, or supported from below. It utilizes a single membrane thermal actuator with an integrated piston to provide shade whenever the ambient temperature rises above 70 degrees F. Alternately, the thermal parasol can be solar powered, with the shade fabric covering up the collector to provide a recursive loop. This loop could be used to create a shading device that oscillates between open and closed at a rate that is dependant on the amount of solar energy hitting the collector.

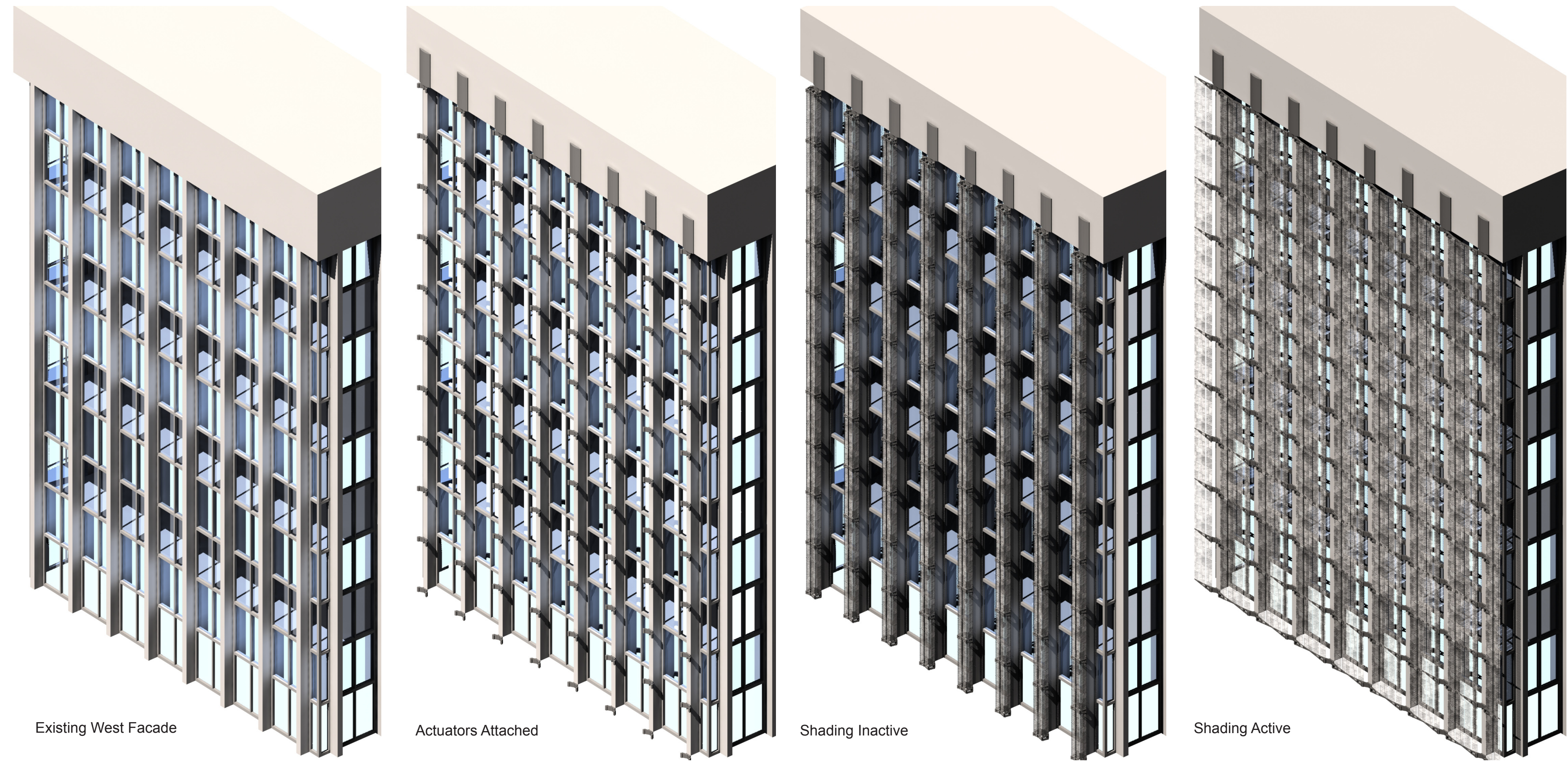
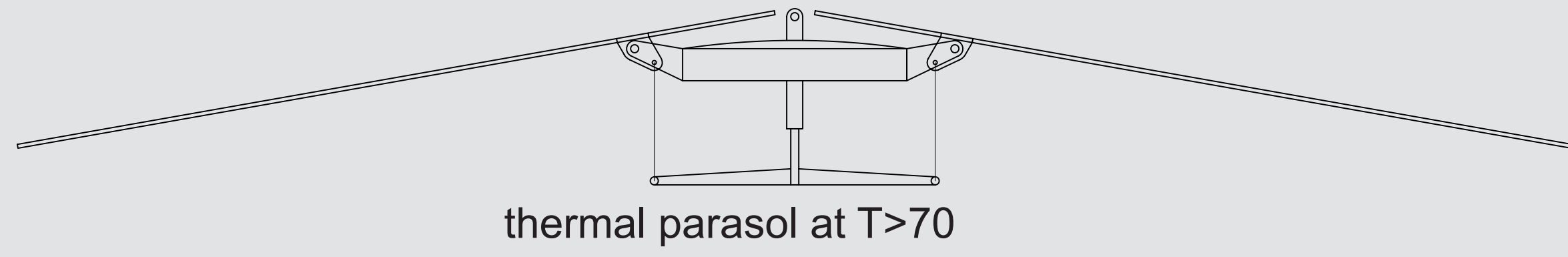
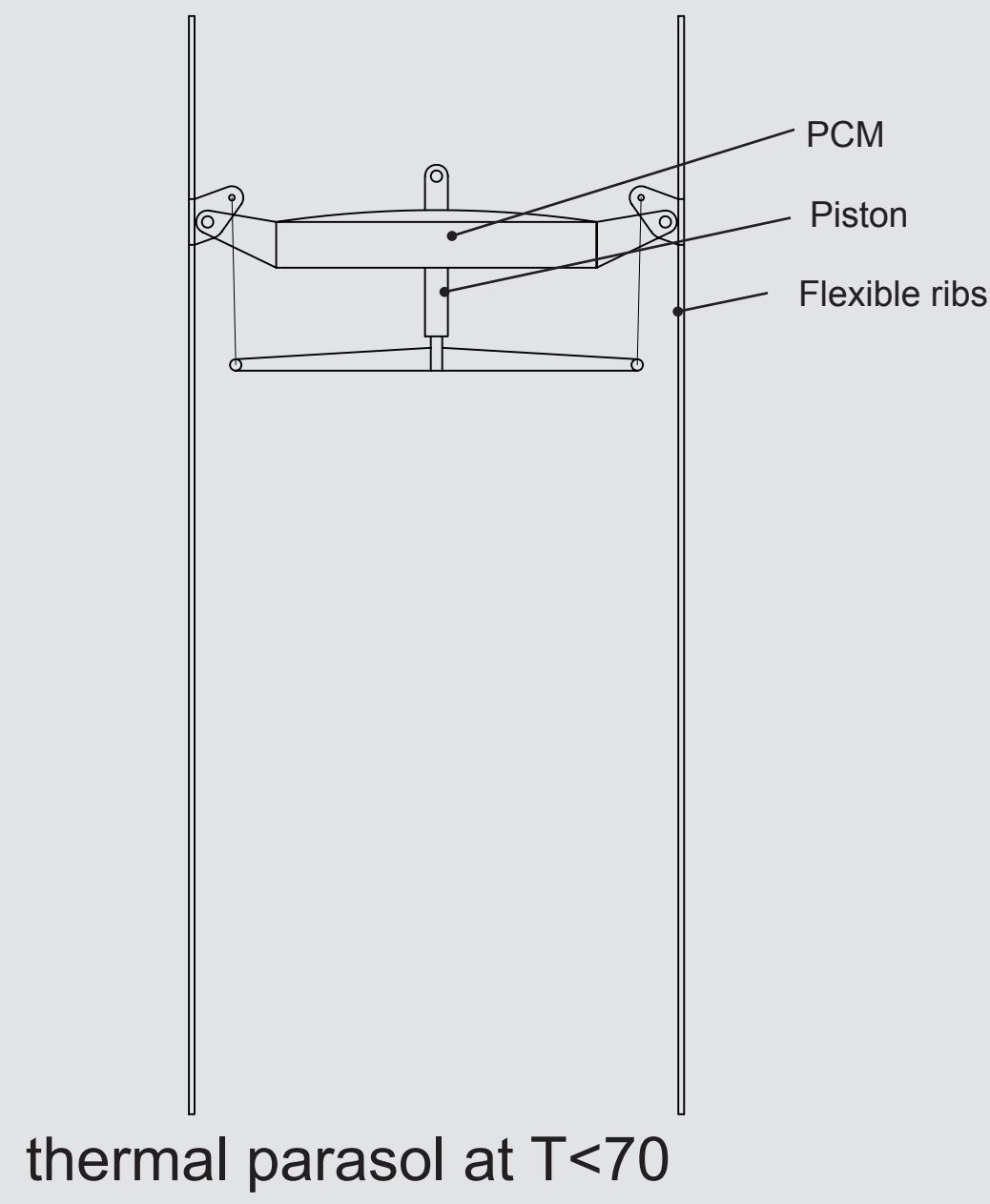

West Facade Retrofit

the self contained nature of thermal actuators makes them strong candidates for updating old buildings to reduce thermal loads. Thermal actuators are self powered, and require no external input of any kind to function. This design for the adaptation of an existing west facade uses a solar powered thermal actuator to drive a shading device. The shading device draws its energy from the sun, and so as the sun hits the west facade, the shade automatically deploys. At all other times, the shading devices retracts to open up views from inside the building.

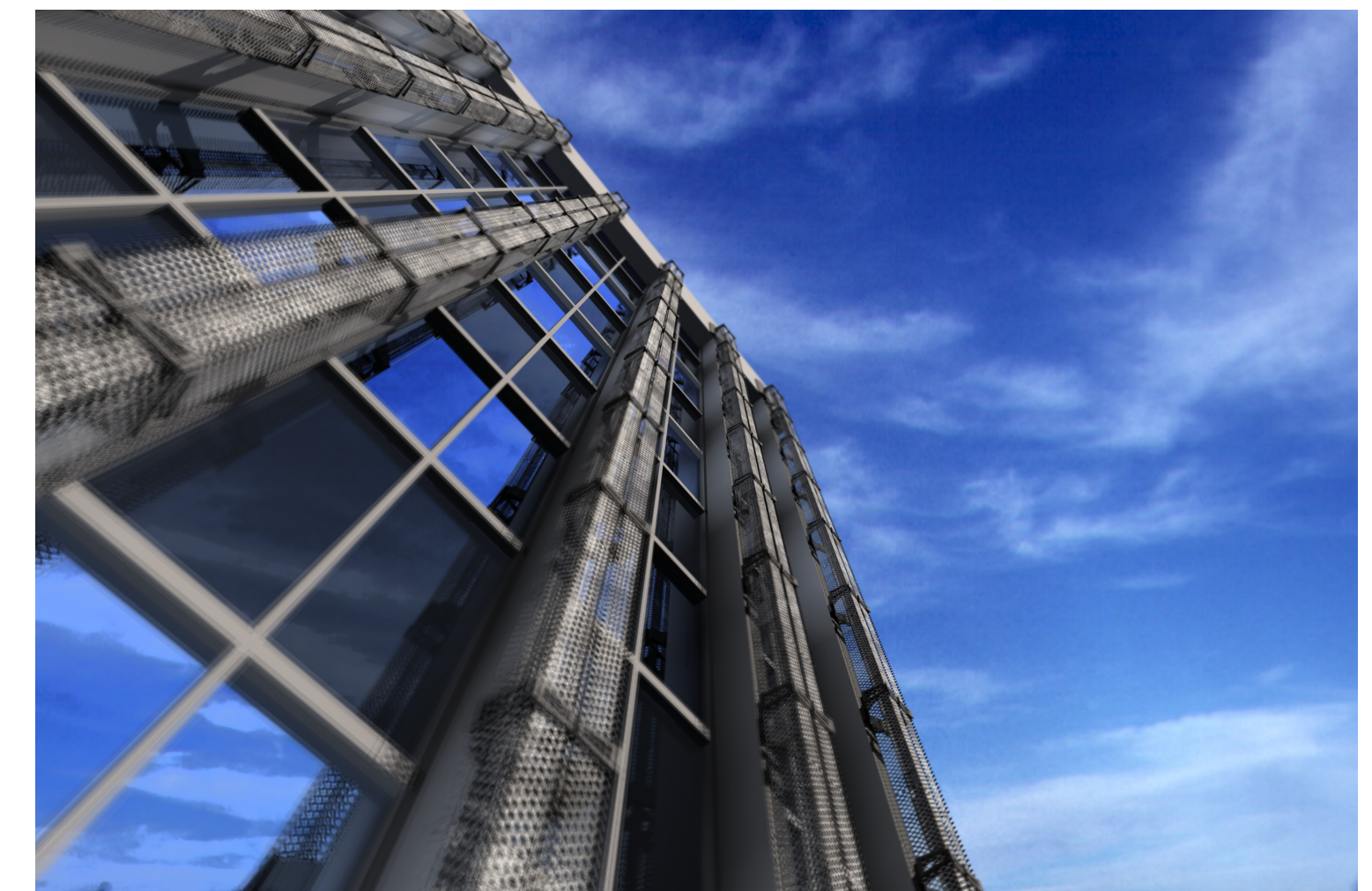
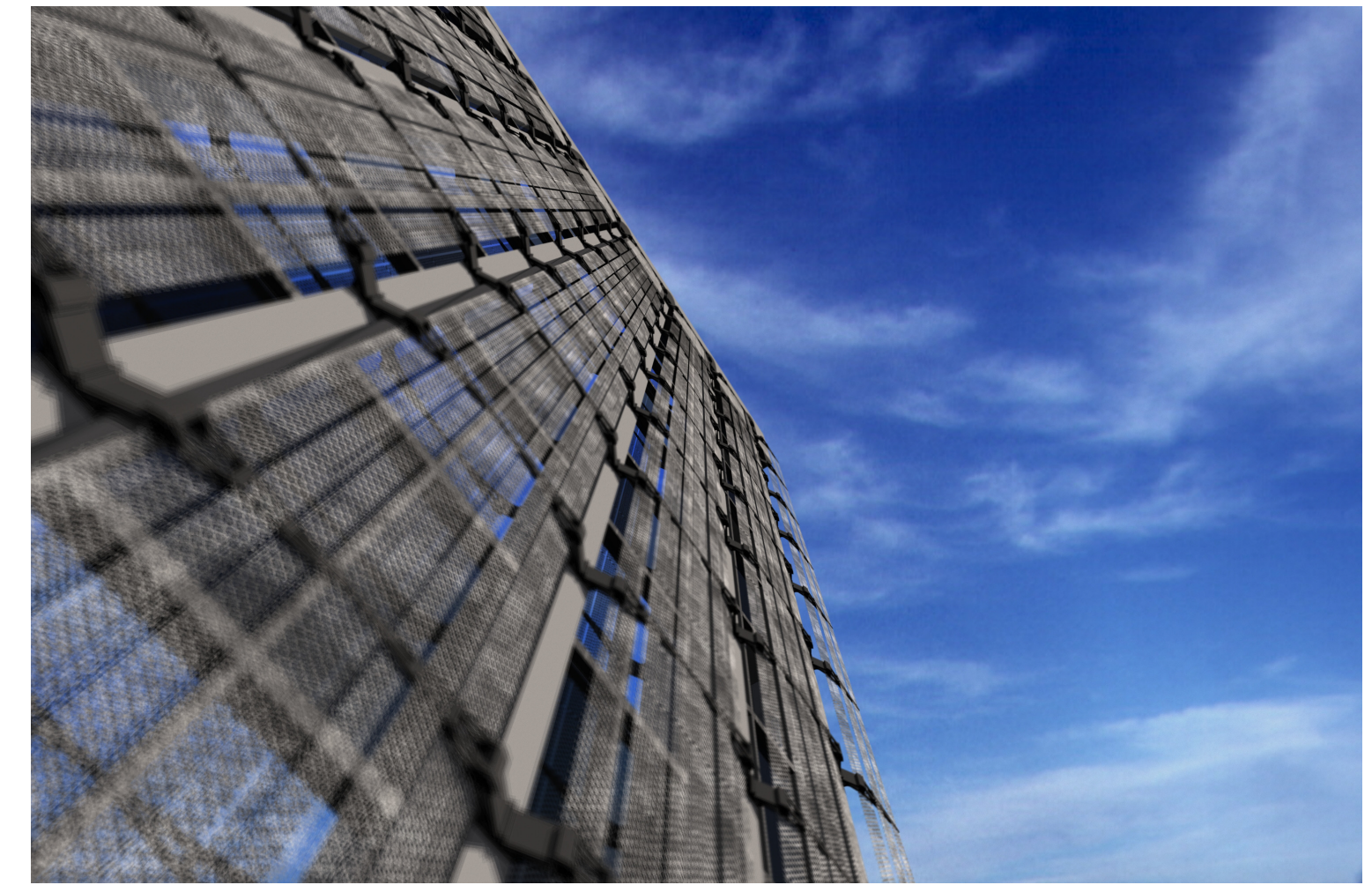
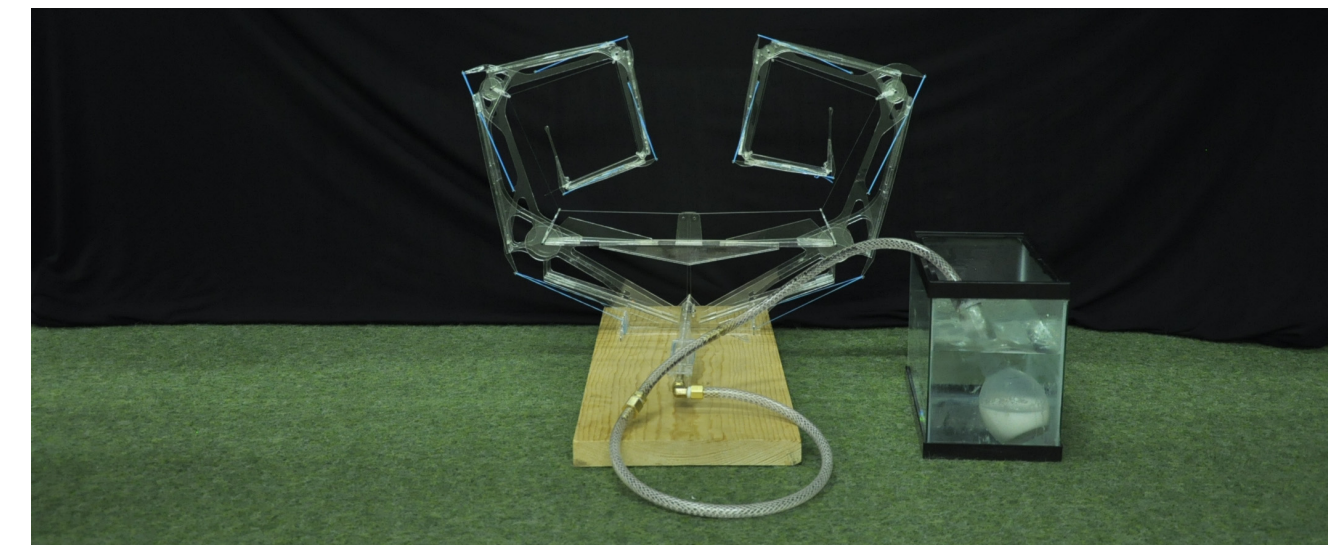
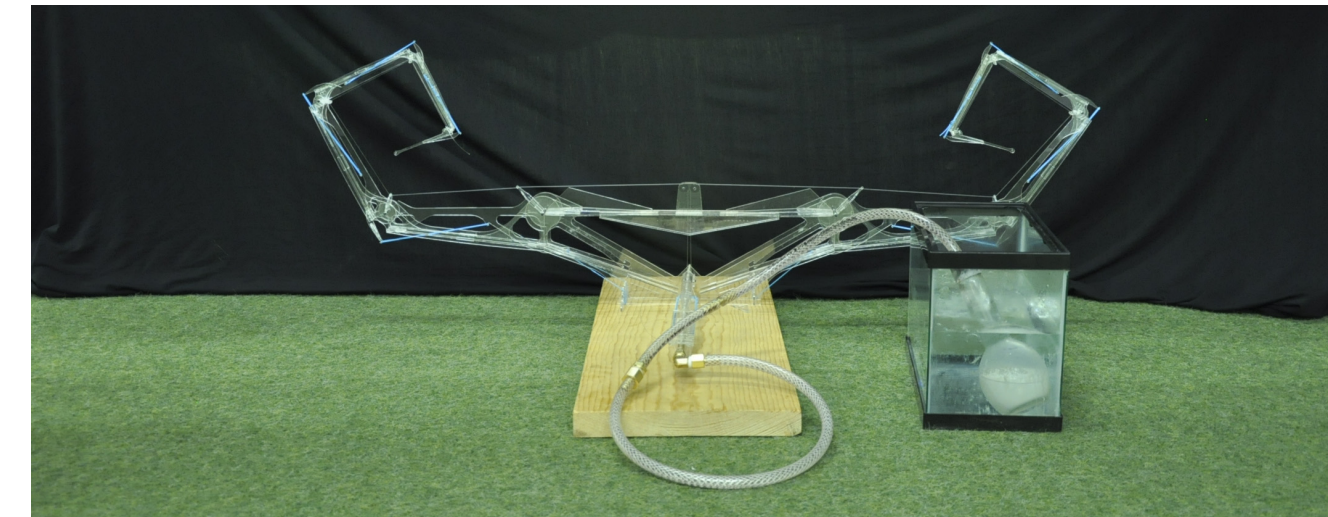
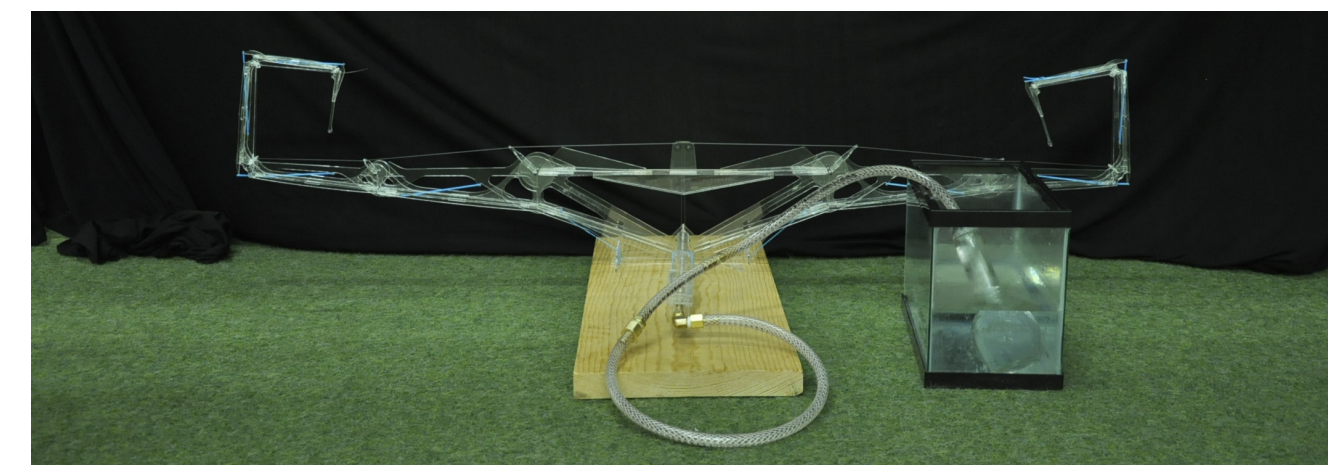
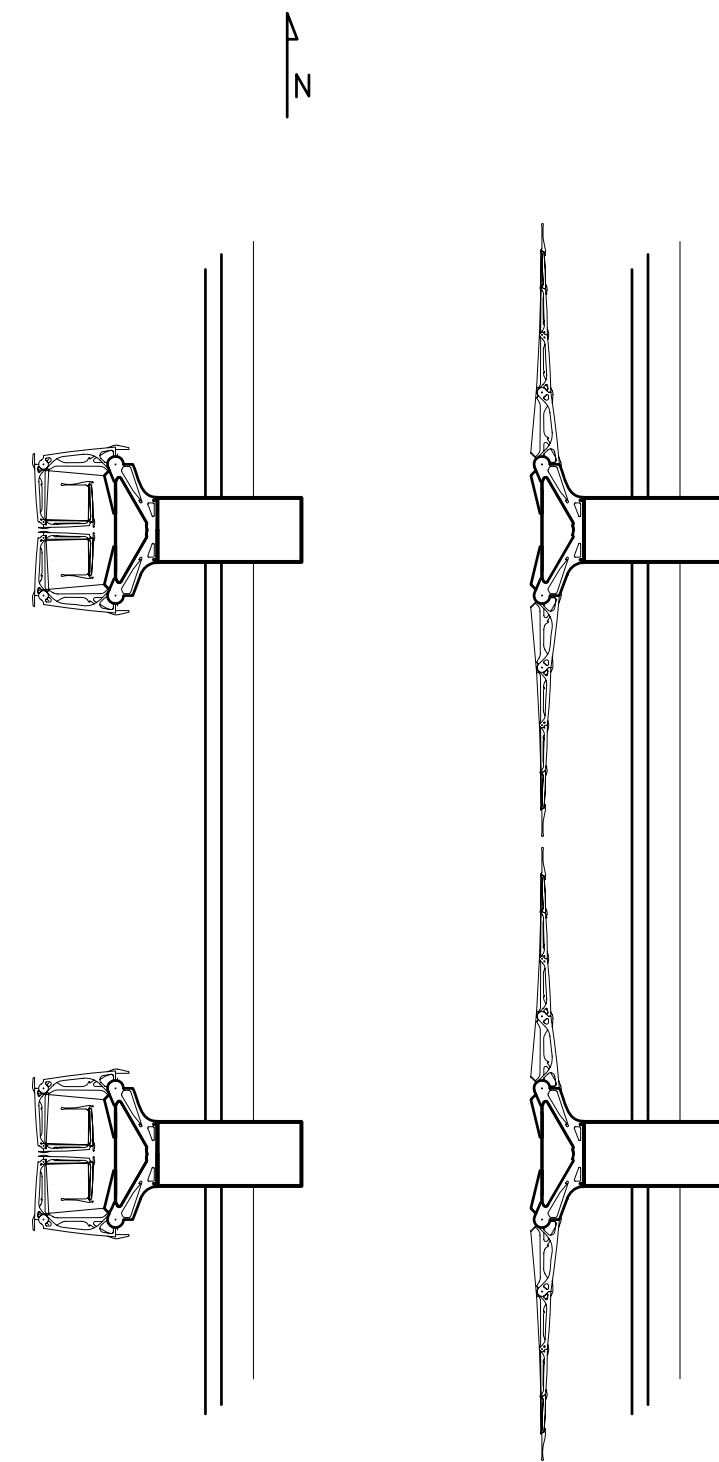
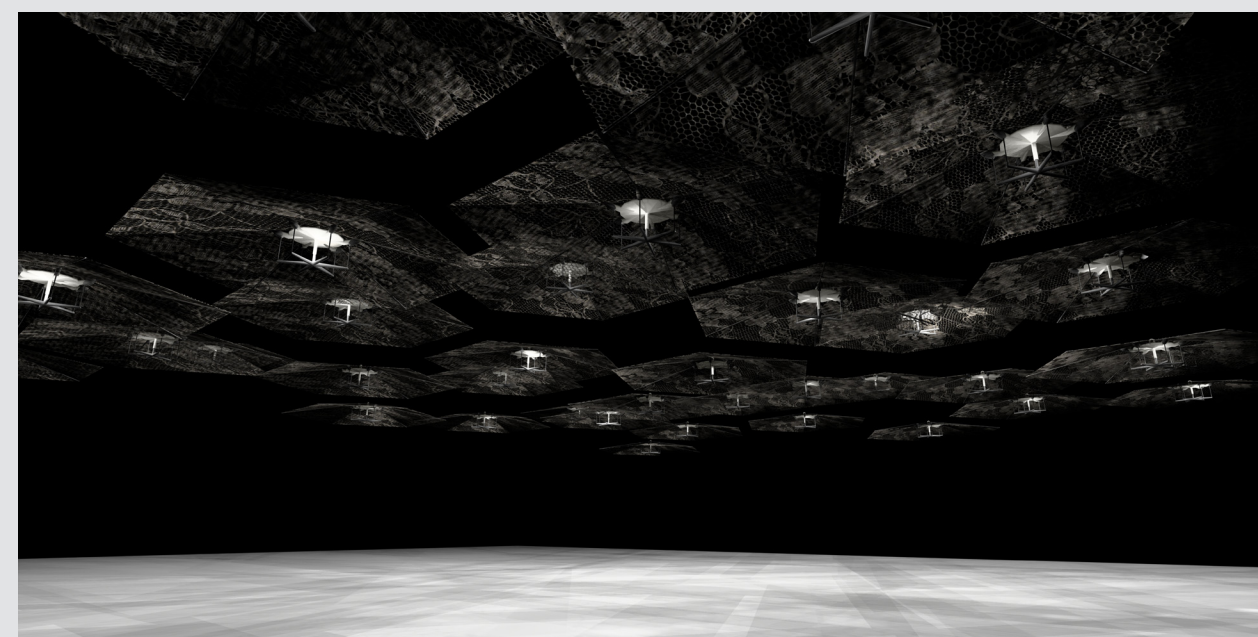
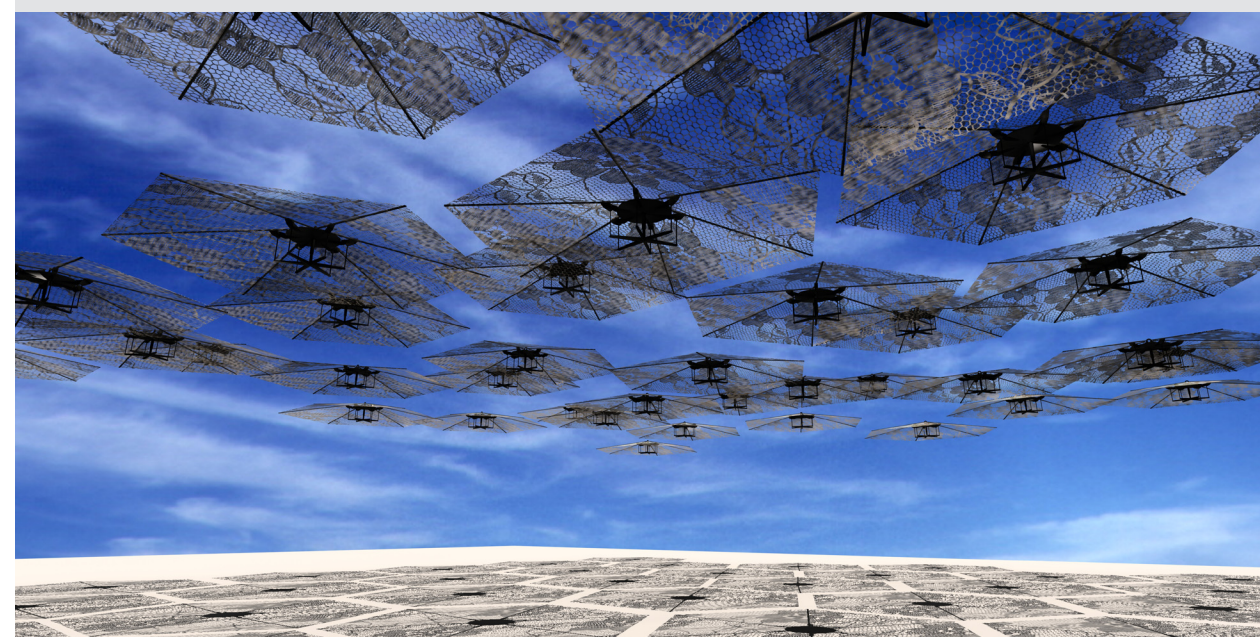
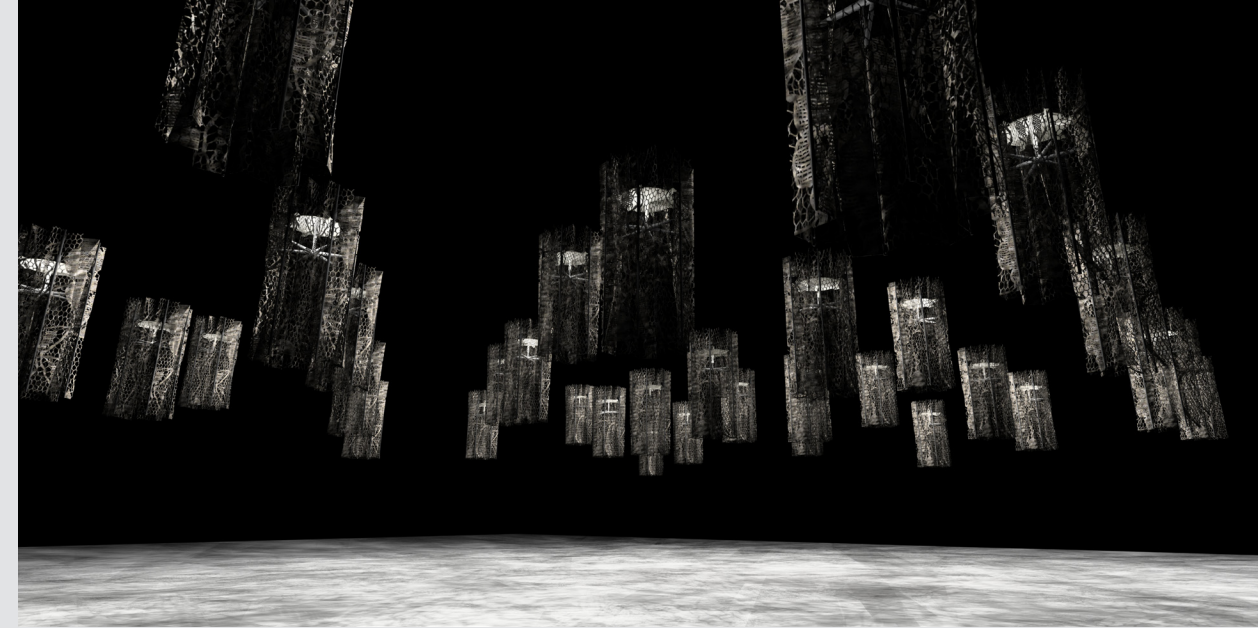
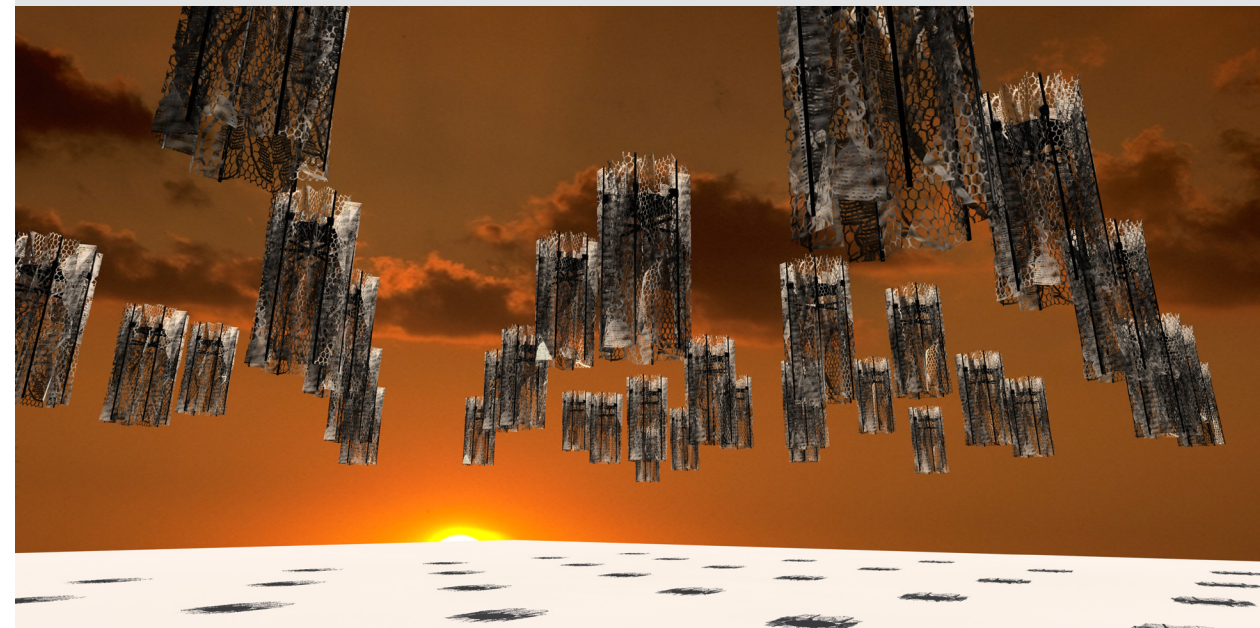

Shade

Thermally Actuated Vortex Generator

The vortex generator is an experiment in creating turbulence through shear patterns generated by diverging the local vectors in a laminar flow. Thermal Actuators could then be embedded into extruded aluminum fins to create variable turbulence based on the surface temperature of the fin.

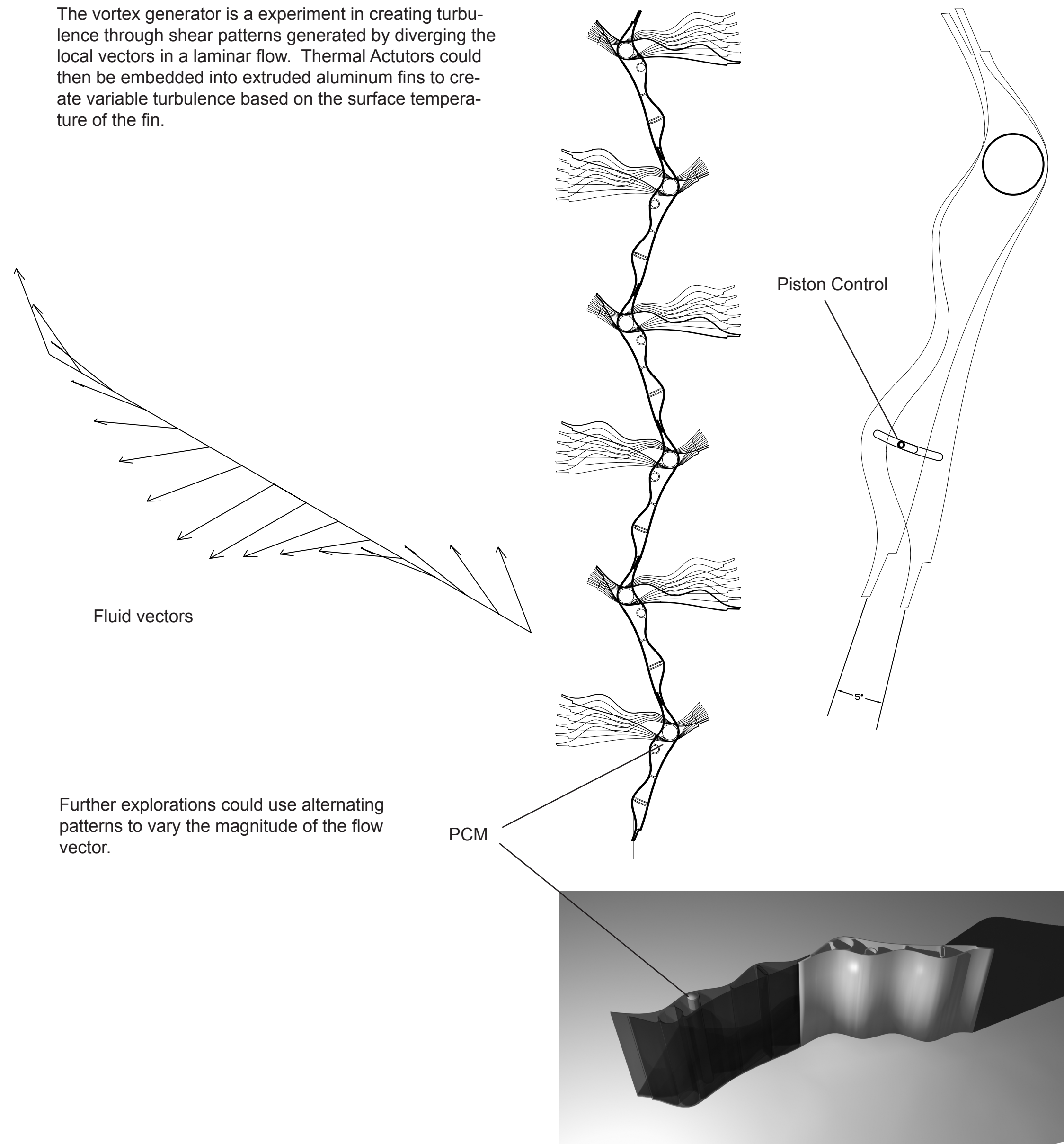

Further explorations could use alternating patterns to vary the magnitude of the flow vector.

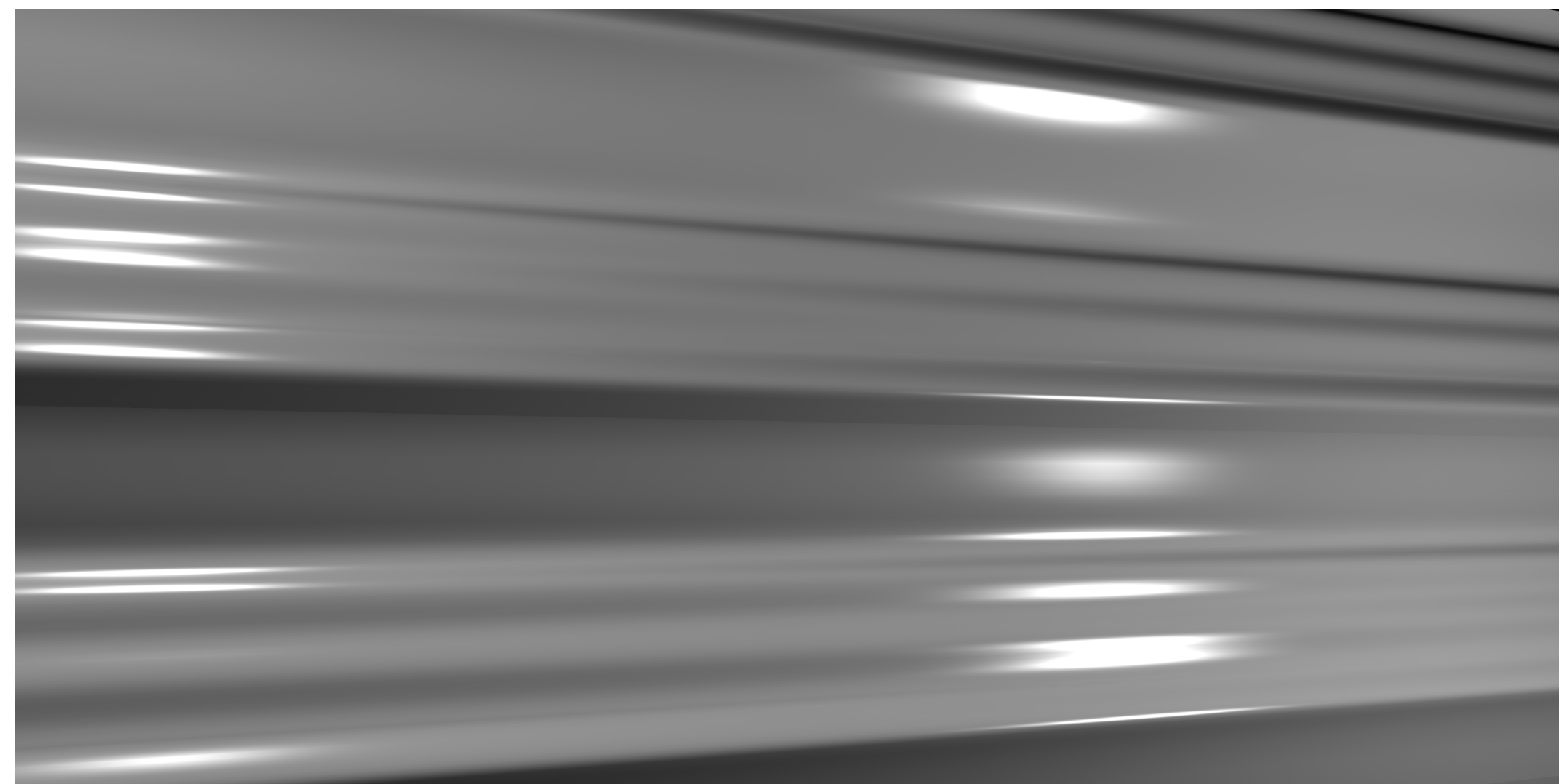
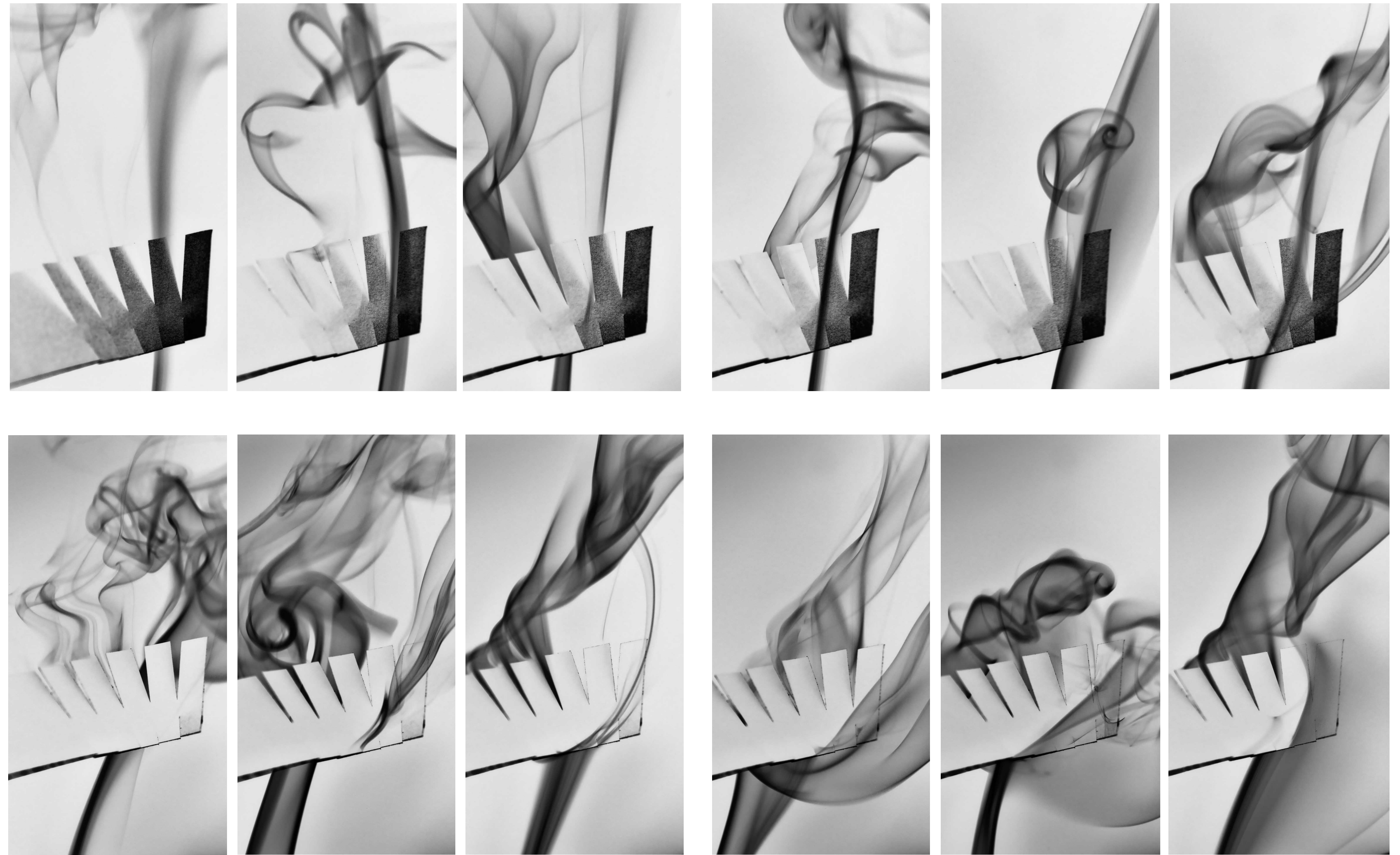

System Closed



System Open - Laminar Condition

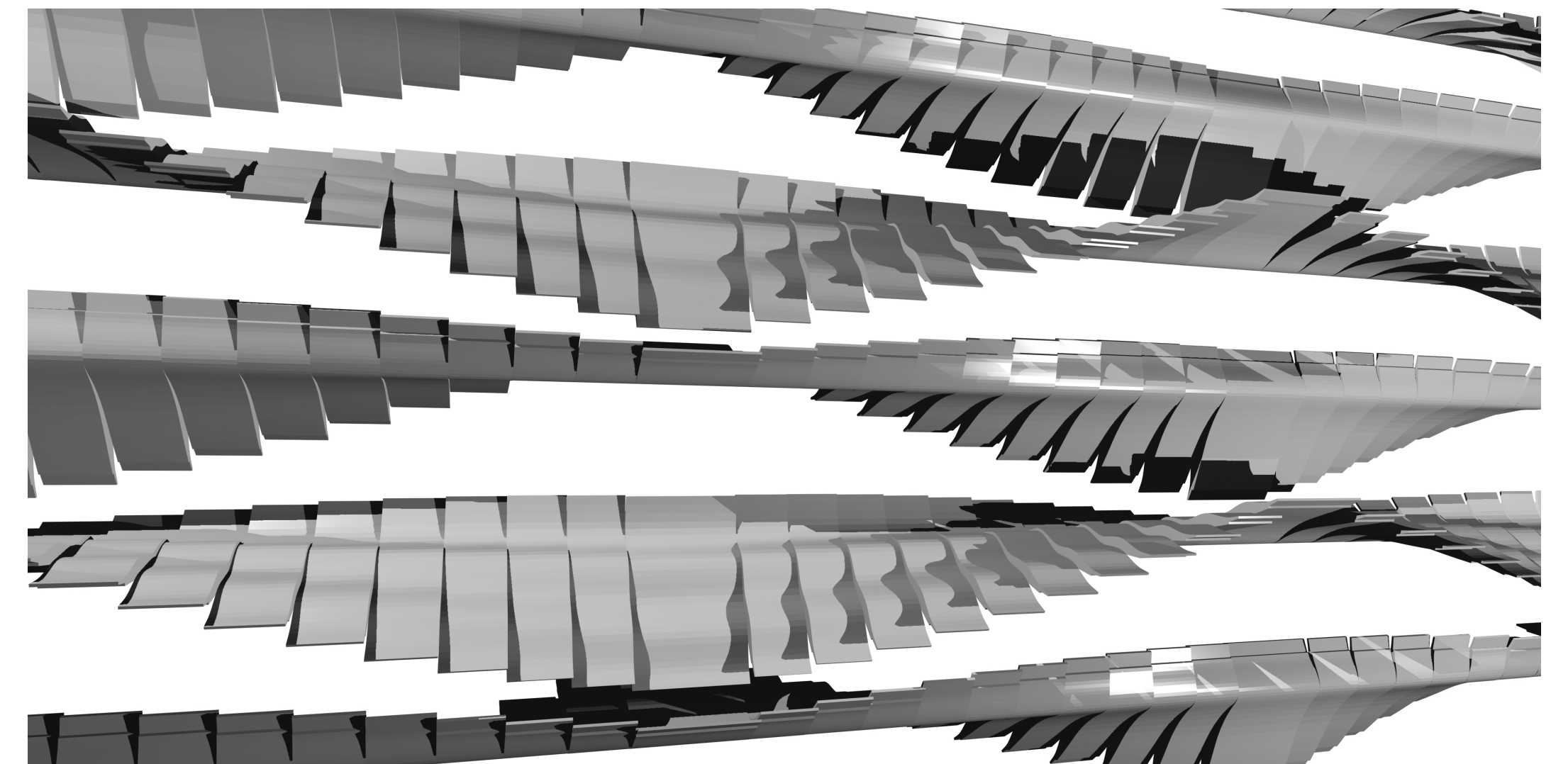

System Open - Possible Vortex Condition